

Rocket Activity

Foam Rocket

Objective

Students will learn about rocket stability and trajectory with rubber band-powered foam rockets.

Description

Students will construct rockets made from pipe insulating foam and use them to investigate the trajectory relationship between launch angle and range in a controlled investigation.

Materials

30 cm-long piece of polyethylene foam pipe insulation (for 1/2" size pipe)
 Rubber band (size 64)
 Styrofoam food tray
 3 8" plastic cable wraps
 75 cm of ordinary string
 Scissors
 Meter stick
 Press tack
 Washer or nut
 Quadrant plans printed on card stock
 Rocket construction instructions
 Experiment data sheet
 Masking tape
 Launch record sheet
 For class - tape measure

National Science Content Standards

Unifying Concepts and Processes

- Evidence, models, and explanation
- Change, constancy, and measurement

Science as Inquiry

- Abilities necessary to do scientific inquiry

Physical Science

- Position and motion of objects
- Motions and forces

Science and Technology

- Abilities of technological design

National Mathematics Content Standards

- Number and Operations
- Algebra
- Geometry
- Measurement
- Data Analysis and Probability

National Mathematics Process Standards

- Reasoning and Proof
- Communication
- Connections

Management

Select a large room with a high ceiling for the launch range, such as a cafeteria or gymnasium. Place markers on the floor at 1 meter intervals starting at 5 meters and going to 20 meters. If it is a calm day, the investigation can be conducted outside. Although the rockets can be launched outside on windy days, the wind becomes an uncontrollable variable that will invalidate the results. Prepare some sample rocket fins to show how they are constructed. Refer to the construction

page for details. Before conducting the investigation, review the concept of control. In this investigation, control will be how much the rubber band is stretched when launching the rockets. The experimental variable will be the angle of launch. Students will compare the launch angle with the distance the rocket travels. Organize students into teams of three. One student is the launcher. The second student confirms the launch angle and gives the launch command. The third student measures the launch distance, records it, and returns the rocket to the launch site for the next flight. The experiment is repeated twice more with students switching roles. The distances flown will be averaged, and students will predict what the best launch angle should be to obtain the greatest distance from the launch site.

Background

The foam rocket flies ballistically. It receives its entire thrust from the force produced by the elastic rubber band. The rubber band is stretched. When the rocket is released, the rubber band quickly returns to its original length, launching the foam rocket in the process. Technically, the foam rocket is a rocket in appearance only. The thrust of real rockets typically continues for several seconds or minutes, causing continuous acceleration, until propellants are exhausted. The foam rocket gets a quick pull and thrusting is over. Once in flight, it coasts. Furthermore, the mass of the foam rocket doesn't change in flight. Real rockets consume propellants and their total mass diminishes. Nevertheless, the flight of a foam rocket is similar to that of real rockets. Its motion and course is affected by gravity and by drag or friction with the atmosphere. The ability to fly foam rockets repeatedly (without refueling) makes them ideal for classroom investigations on rocket motion.

The launch of a foam rocket is a good demonstration of Newton's third law of motion. The contraction of the rubber band produces an action force that propels the rocket forward while exerting an opposite and equal force on the launcher. In this activity, the launcher is a meter stick held by the student.

Tip Be sure the range-measuring student measures where the rocket touches down and not where the rocket ends up after sliding or bouncing along the floor.

In flight, foam rockets are stabilized by their fins. The fins, like feathers on an arrow, keep the rocket pointed in the desired direction. If launched straight up, the foam rocket will point upward until it reaches the top of its flight. Both gravity and air drag put act as brakes. At the very top of the flight, the rocket momentarily becomes unstable. It flops over as air catches the fins and becomes stable again when it falls back nose forward.

When the foam rocket is launched at an angle of less than 90 degrees, it generally remains stable through the entire flight. Its path is an arc whose shape is determined by the launch angle. For high launch angles, the arc is steep, and for low angles, it is broad.

When launching a ballistic rocket straight up (neglecting air currents) the rocket will fall straight back to its launch site when its upward motion stops. If the rocket is launched at an angle of less than 90 degrees, it will land at some distance from the launch site. How far away from the launch site is dependent on four things. These are:

- gravity
- launch angle
- initial velocity
- atmospheric drag

Gravity causes the foam rocket to decelerate as it climbs upward and then causes it to accelerate as it falls back to the ground. The launch angle works with gravity to shape the flight path. Initial velocity and drag affects the flight time.

In the investigation, students will compare the launch angle to the range or distance the foam rocket lands from the launch site. Launch angle is the independent variable. Gravity can be ignored because the acceleration of gravity will remain the same for all flight tests.

Atmospheric drag can be ignored because the same rocket will be flown repeatedly. Although students will not know the initial velocity, they will control for it by stretching the rubber band the same amount for each flight. The dependent variable in the experiment is the distance the rocket travels.

Assuming student teams are careful in their control of launch angles and in the stretching of the launch band, they will observe that their farthest flights will come from launches with an angle of 45 degrees. They will also observe that launches of 30 degrees, for example, will produce the same range as launches of 60 degrees. Twenty degrees will produce the same result as 70 degrees, etc. (Note: Range distances will not be exact because of slight differences in launching even when teams are very careful to be consistent. However, repeated launches can be averaged so that the ranges more closely agree with the illustration.)

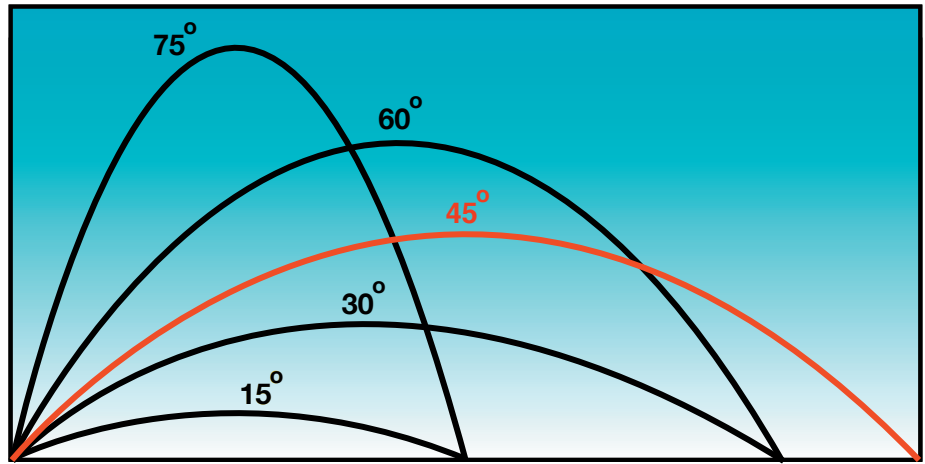

Launch angle vs. range for rockets with the same initial launch velocity

Procedures Constructing a Foam Rocket

1. Using scissors, cut one 30-cm length of pipe foam for each team.
2. Cut four equally spaced slits at one end of the tube. The slits should be about 8 to 10 cm long. The fins will be mounted through these slits.
3. Tie a string loop that is about 30 cm long.
4. Slip one end of a cable wrap through the string loop and through the rubber launch band.

Join the cable wrap to form a loop and tighten it down to a circle approximately 1 to 2 cm in diameter. The end of the wrap can be trimmed off with scissors or left.

5. Thread the cable wrap with string and rubber launch band through the hole in the foam tube. The string should stick out the rear end of the rocket and the rubber band out the nose. Position the plastic loop about 3 cm back from the nose.
6. Tighten the second cable wrap securely around the nose of the rocket. It should be positioned so that the cable wrap loop inside the rocket is unable to be pulled out the nose when the rubber band is stretched. **Caution students not to pull on the string.** The string should only be pulled during launches when the rubber band is held from the other end. Trim off the excess cable wrap end.
7. Cut fin pairs from the foam food tray or stiff cardboard. Refer to the fin diagram.

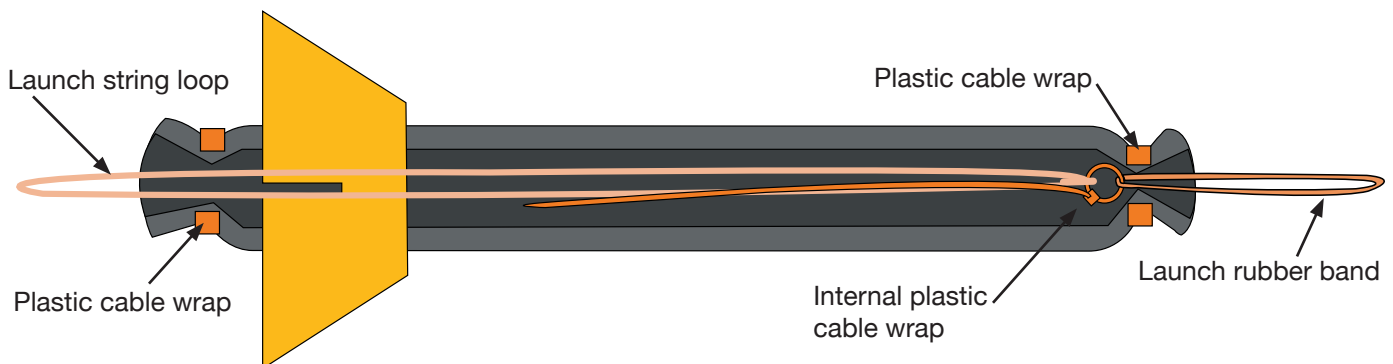

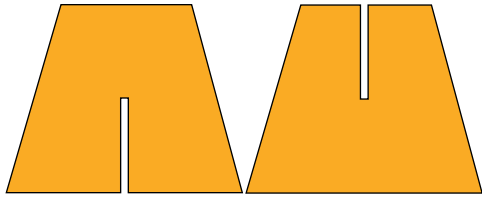

Cut slots the same width as the thickness of the fin stock.

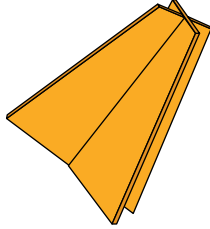

Nest fins together.

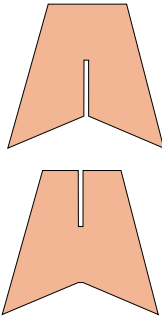

Different fin shapes can be used.

Both fin pairs should be notched so that they can be slid together as shown in the diagram. Different fin shapes can be used, but they should still “nest” together.

8. Slide the nested fins into the slits cut in the rear end of the rocket. Make sure the string loop hangs out the “engine” end.
9. Tighten the third cable wrap around the rear of the rocket. This will hold the fins in place. Trim off the excess cable wrap end.

Procedure Making the Launcher

1. Print the quadrant pattern (page 78) on card stock paper.
2. Cut out the pattern and fold it on the dashed line.
3. Tape the quadrant to the meter stick so that the black dot lies directly over the 60 cm mark on the stick.
4. Press a push tack into the black dot.

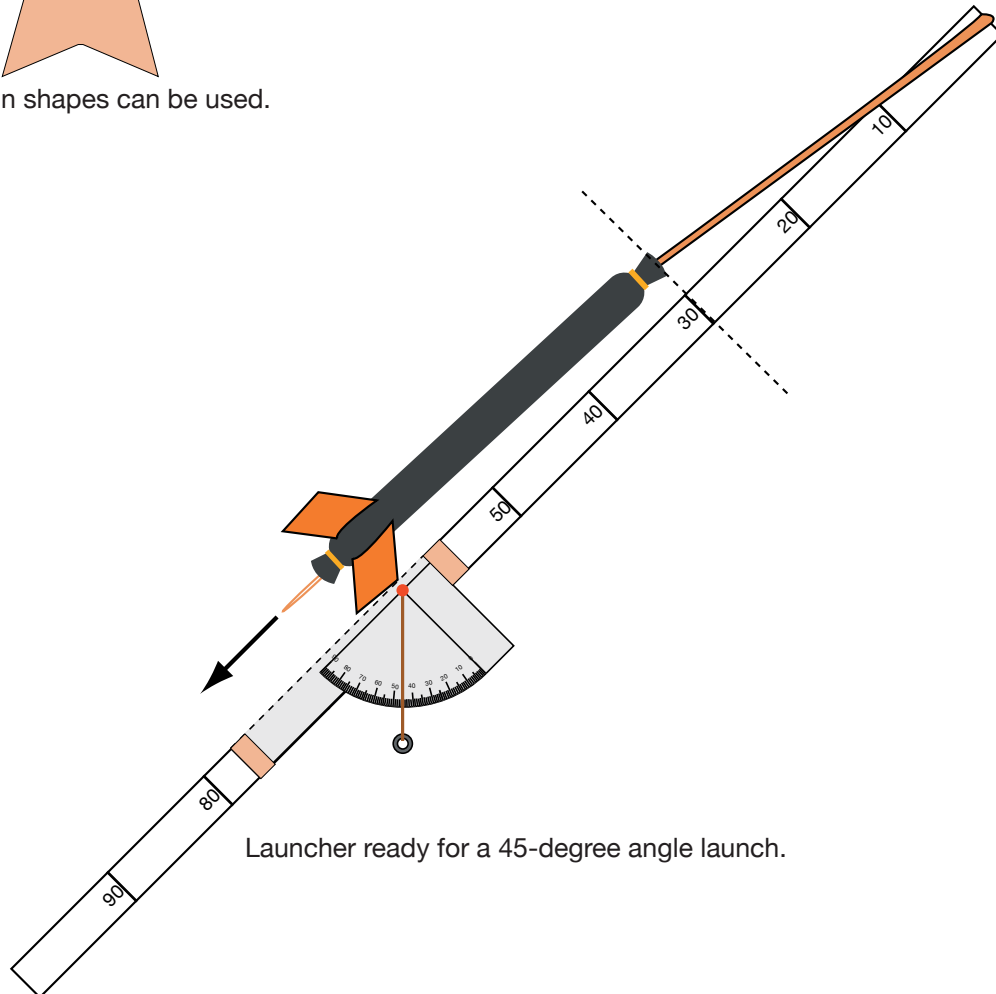

Launcher ready for a 45-degree angle launch.

5. Tie a string to the push tack and hang a small weight, such as a nut or a washer, on the string. The weight should swing freely.
6. Refer to the diagram to see how the launcher is used.

Discussion

- *Why didn't the experiment protocol call for launching at 0 and 90 degrees?*
Assuming a perfect launch, a rocket launched straight upwards should return to the launch pad. Any variation in the impact site will be due to air currents and not to the launch angle. A rocket launched horizontally will travel only as long as the time it takes to drop to the floor.
- *Shouldn't the rocket be launched from the floor for the experiment?*
Yes. However, it is awkward to do so. Furthermore, student teams will be measuring the total distance the rocket travels, and consistently launching from above the floor will not significantly affect the outcome.

Assessment

- Have student teams submit their completed data sheets with conclusions.
- Have students write about potential practical uses for the foam rocket (e.g., delivering messages).

Extensions

- For advanced students, the following equation can be used for estimating ranges. (g is the acceleration of gravity on Earth)

$$\text{Range} = \frac{V_o}{g} \sin 2A$$

V_o = Initial Velocity

g = 9.8 meters/second²

A = Launch Angle

Students will have to determine initial velocity. If available, an electronic photogate (science lab probeware) with timer can be used for determining the initial velocity. Otherwise, challenge students to devise a method for estimating initial velocity. One approach might be to launch the rocket horizontally from a tabletop and measure the horizontal distance the rocket travels as it falls to the floor. Using a stopwatch, measure the time the rocket takes to reach the floor. If the rocket takes 0.25 seconds to reach the floor and traveled 3 meters horizontally while doing so, multiply 3 meters by 4. The initial velocity will be 12 meters per second. Students should repeat the measurement several times and average the data to improve their accuracy. (This method assumes no slowing of the rocket in flight due to air drag.)

- Different kinds of fins can be constructed for the foam rocket. Try creating a space shuttle orbiter or a future rocket plane for exploring the atmosphere of other planets.

Build a Foam Rocket

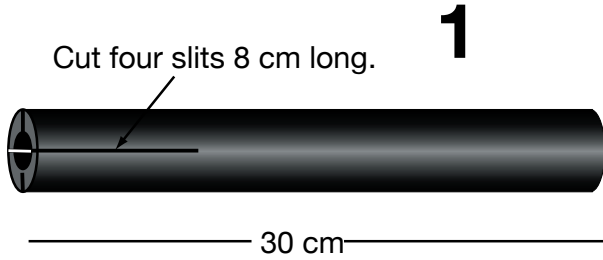

Cut out fins with notches.

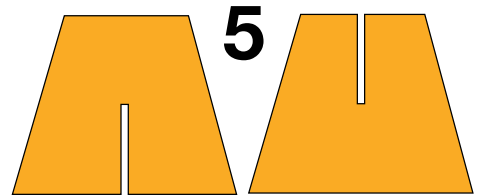

2

Join 30 cm string loop and rubber band with cable wrap.

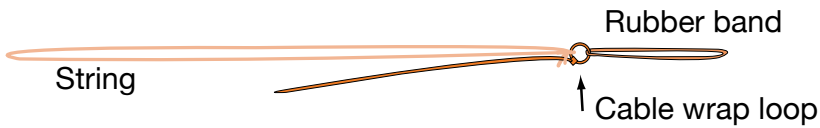

Slide fins together.

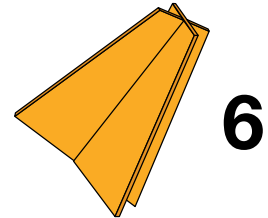

Slip string, cable wrap loop, and rubber band inside.



Close off end with cable wrap (tight!).

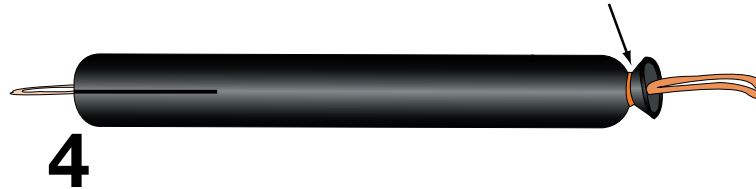

Slide fins into slits.



Close off end with cable wrap (tight!).

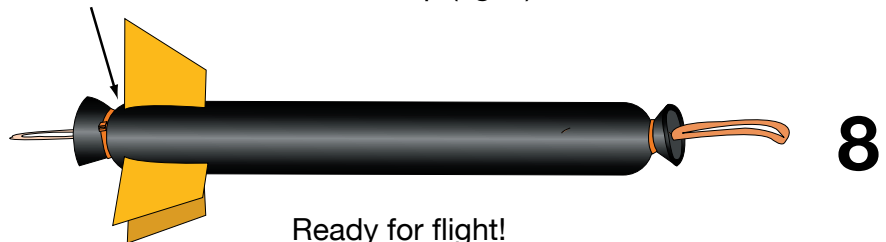

Launcher Quadrant Pattern

(Actual Size)

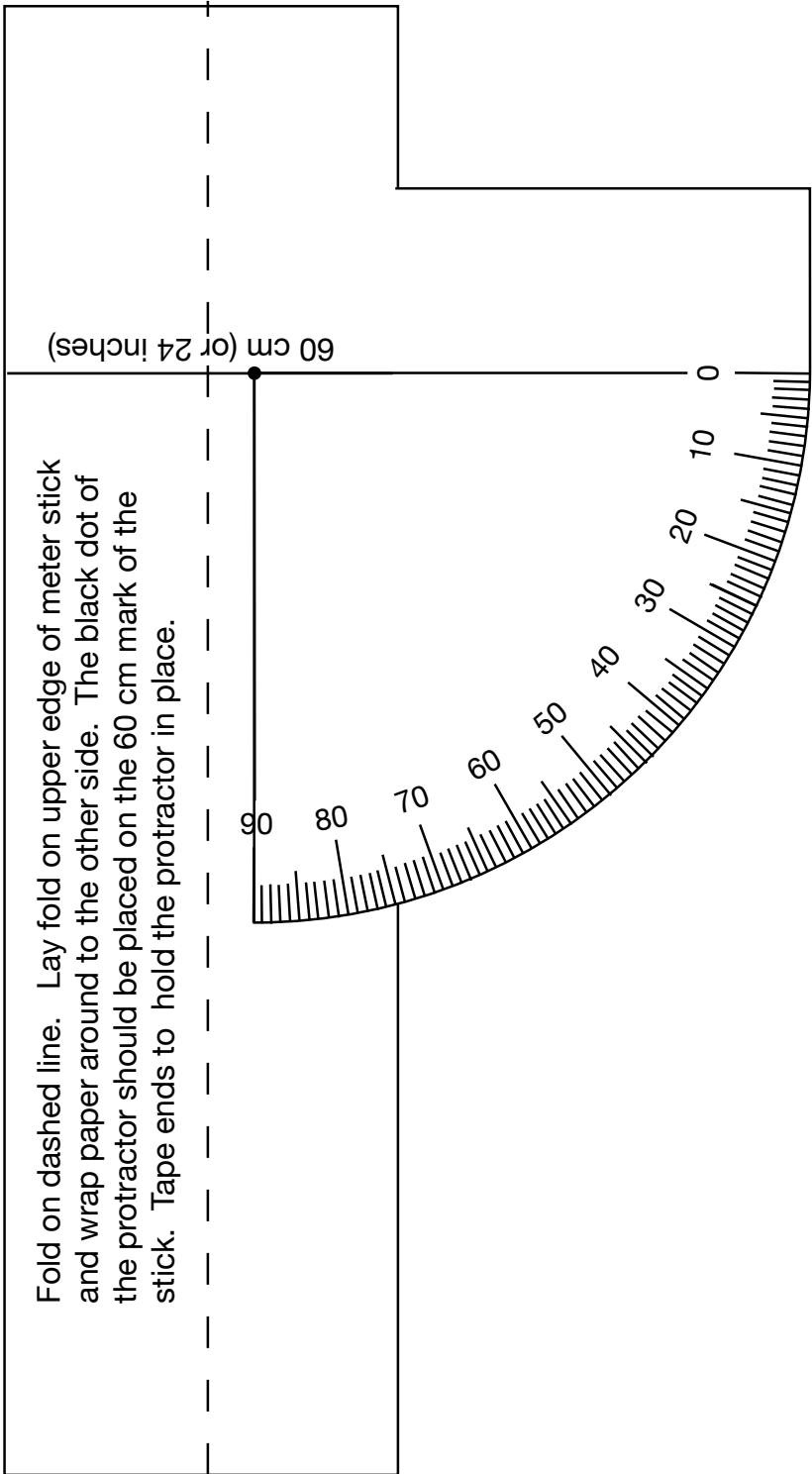

Rocket Range Experiment

Team Member _____
Names: _____

1. Assign duties for your team. You will need the following positions:
Launch Director, Launcher, and Range Officer. (Team members will switch jobs later.)
2. First Launch:
Launcher - Attach the rocket to the launcher and pull back on string until its tail reaches the 60-cm mark. Tilt the launcher until it is pointing upwards at an angle of between 10 and 80 degrees. Release the rocket when the launch command is given.
Launch Director - Record the angle on the data table. Give the launch command. Record the distance the rocket travels.
Range Officer - Measure the distance from the launcher to where the rocket hits the floor (not where it slides or bounces to). Report the distance to the launch director and return the rocket to the launcher for the next launch.
3. Repeat the launch procedures four more times but for different angles of from 10 and 80 degrees.
4. Run the entire experiment twice more but switch jobs each time. Use different launch angles.
5. Compare your data for the three experiments.

Data Table 1

Launch Angle	Distance

Data Table 2

Launch Angle	Distance

Data Table 3

Launch Angle	Distance

From your data, what launch angle should you use to achieve the greatest distance from the launch site? Test your conclusion.

Why didn't the instructions ask you to test for 0 and 90 degrees?