

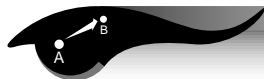

# Building a Microscope

## Objective



The student will construct a simple low-power microscope from two converging lenses. See pages 59–62. The student will be able to see how a microscope works.

## Theory



In a microscope, the lens, placed next to the object to be magnified, is called the objective lens, while the lens held next to the eye is called the eyepiece. The eyepiece should have a focal length of about 25 millimeters, while the objective should have a focal length of 25 millimeters or less to be suitable for building a microscope. The distance to the enlarged image formed by the objective lens is 160 millimeters. The enlarged image formed by the objective lens is magnified by the eyepiece.

## Science and Mathematics Standards



### Science Standards

- Science as Inquiry
- Physical Science

### Mathematics Standards

- Problem Solving
- Communication
- Connection
- Computation/Estimation
- Measurement

## Materials



- 2 converging lenses (convex lenses)
- telescoping tubes (mailing tubes)
- a selection of materials to view with the microscope
- a laboratory microscope



## Procedures

A-B  
C-D

This microscope will be constructed using two converging lenses of short focal length suitable for a microscope as described in the theory section on the previous page. Two cardboard telescoping tubes that fit snugly one inside the other will be the body of the microscope.

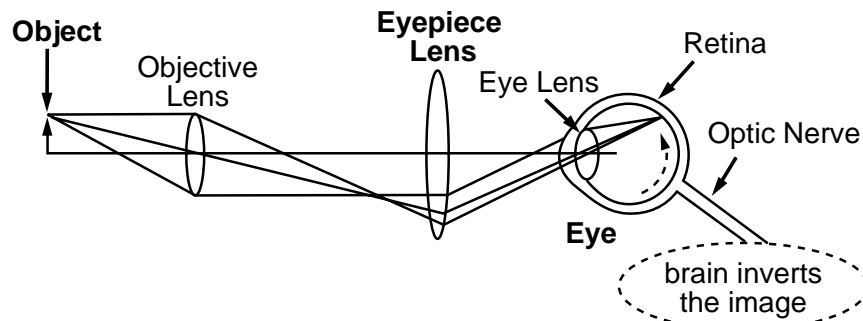

1. To build your microscope, place the lens identified as the eyepiece (ocular) lens on the end of the cardboard tube having the smallest diameter.
2. Take the other lens, the one identified as the objective lens, and place it on the end of the cardboard tube having the largest diameter.
3. Slide the two cardboard tubes together. You have now assembled a simple microscope. View several items. Slide the two cardboard tubes in and out until you have a clear image.

## Observations, Data, and Conclusions



1. List the various objects that you examined through your microscope. Find two additional items to examine.
2. Take two of the objects that you examined through your microscope and look at them through the laboratory microscope.
3. What differences did you observe when you looked through the microscope you made and the laboratory microscope?
4. Which is the better microscope?
5. What makes that microscope better?





## Construction of a Microscope— A File Folder Microscope

### Materials



- 2 lenses (one 46 mm and one 28 mm)
- 2 manila file folders
- carpenter's wood glue
- dowel
- small wooden block
- screw with wing nut
- scissors
- black liquid shoe polish or dye
- rubber bands
- small piece of pipe
- clear varnish (optional)

### Procedures



1. From the manila file folder, cut the biggest piece of uncreased paper possible. Pull the piece of folder back and forth over the sharp edge of a desk so that the paper will curve or curl. After the entire piece of folder has begun to curl, take the small piece of pipe and roll the paper around it. As the paper is rolled onto the pipe apply the glue to the entire inside surface of the paper. When the first roll is complete, secure it with rubber bands until it is dry.
2. After the paper roll is dry, remove the pipe, and then drip black liquid shoe polish inside the paper tube to coat the entire inside surface of the tube.
3. Next, cut a smaller piece of paper and roll and glue it around the first tube of paper. (For all other instructions, see the illustration on the following page.)



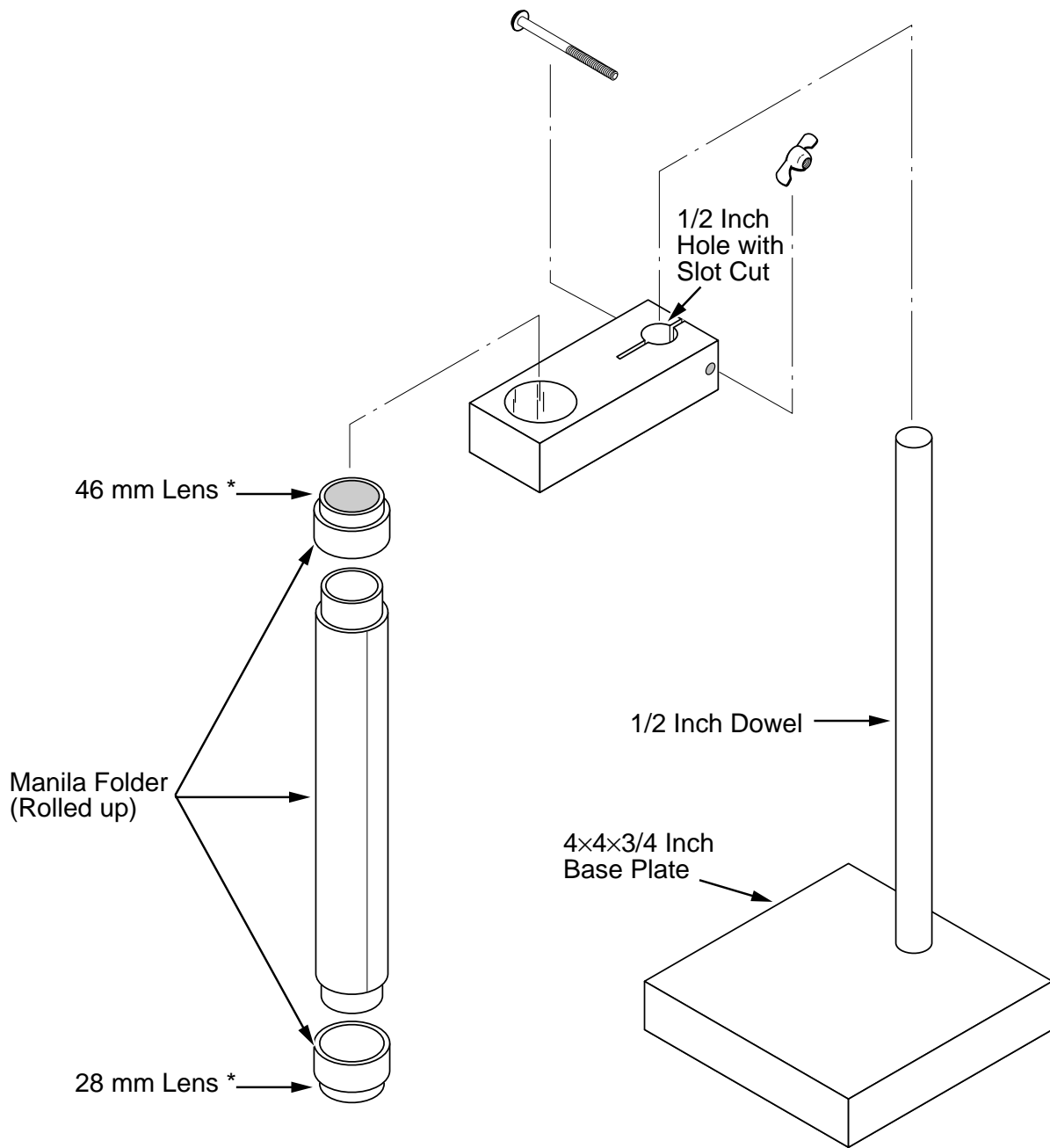

\* Lenses may be obtained from school supply store.

