

Focusing Light With a Lens

Objective



The student will experiment with a converging lens that has a focal point which can be easily measured. Using a lens, the student will observe the image of an object through a lens and will determine the magnification of that lens.

focus at the focal point of the lens. Since it is inconvenient to get infinite distances in the classroom, the following lens equation is used to compute the focal length of a lens:

$$\frac{1}{f} = \frac{1}{D_o} + \frac{1}{D_i}$$

Science and Mathematics Standards



Science Standards

- Science as Inquiry
- Physical Science

Mathematics Standards

- Problem Solving
- Communication
- Connection
- Computation/Estimation
- Measurement

The measured distance of the object, D_o , from the lens, and the measured distance of the image, D_i , are used to compute the focal length, f , of a converging lens. A more convenient form of this equation is

$$f = \frac{D_i D_o}{D_i + D_o}$$

Theory



When light from a source that is an infinite distance away passes through a converging lens, the light will come to a

Materials



- 2 converging lenses
- a white cardboard imaging screen
- a meter stick or metric ruler
- a 12-inch ruler
- a light source (flashlight)
- an object such as an arrow made of tape on the flashlight lens cover





Procedures



Using both lenses, one at a time, complete all the activities in **Part 1**; then complete **Part 2**.

Procedures



Part 1

1. Experiment with the lenses. Hold each lens above a surface such as your hand, the writing on this page, the fabric of your clothes, etc. Adjust the lens until the surface is in focus and you can see the object clearly. At this point, we are using the lens as a magnifier. Details of the object should be sharp.

2. With the 12-inch ruler, measure the distance from the edge of each lens to the image that you have in focus on the paper, as shown. This distance will be known as D_1 for lens No. 1 and D_2 for lens No. 2.

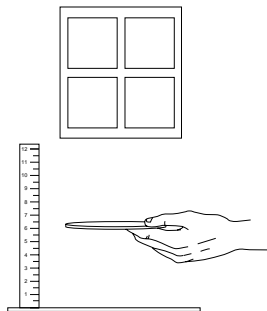

3. Calculate an estimated magnification power for each lens. The magnification of a lens can be explained simply as how many times larger the lens makes the object appear. To perform this calculation, assume that the nearest distance

at which you can see objects clearly is 10 inches. Use the estimated focal length measurement of each lens, D_1 and D_2 , that was measured in the procedure above.

Observations, Data, and Conclusions



1. Using the following equation, calculate an estimate of the magnification for each lens:

$$M = \frac{10}{D}$$

(inches) near distance
for clear vision

(inches) estimated
focal length of lens

2. Using the previous equation, compute the magnification (M) of each lens using the distance (D) for each lens.

D_1 for lens No. 1

D_2 for lens No. 2

$$M_1 = \frac{10}{D_1}$$

M_1 for lens No. 1

$$M_2 = \frac{10}{D_2}$$

M_2 for lens No. 2

3. Which lens has the greater magnification?

Procedures



Part 2

In **Part 2**, a more precise measurement of the focal length of the lenses will be made.

1. For this experiment, the object to be focused is a circle of frosty plastic sheet with a geometrical shape on it. This object should be put on the inside of the flashlight lens cap. Turn the flashlight on and place it along the meter stick pointed toward the zero end of the meter stick.
2. Place the white cardboard imaging surface at the zero end of the meter stick.
3. Hold each lens, one at a time, between the light source (flashlight) and the white cardboard imaging surface as shown below.
4. When you have a sharp image of the object on the imaging surface, you will have found the point at which the lens focuses. When you have found a sharp image, hold things still and measure the distances.

5. Measure the object distance (D_o) and the image distance (D_i) of each lens. To find the object distance (D_o), measure the distance from the black arrow on the surface of the flashlight cover glass to the edge of the lens you are holding. To find the image distance (D_i), measure the distance from the white cardboard imaging surface to the edge of the lens you are holding.

Observations, Data, and Conclusions



1. Record the object distance (D_o) and the image distance (D_i) of lens No. 1 and lens No. 2.

(D_o) of lens No. 1 _____ centimeters (cm)

(D_i) of lens No. 1 _____ centimeters (cm)

(D_o) of lens No. 2 _____ centimeters (cm)

(D_i) of lens No. 2 _____ centimeters (cm)

2. How does the focused image compare with the object?

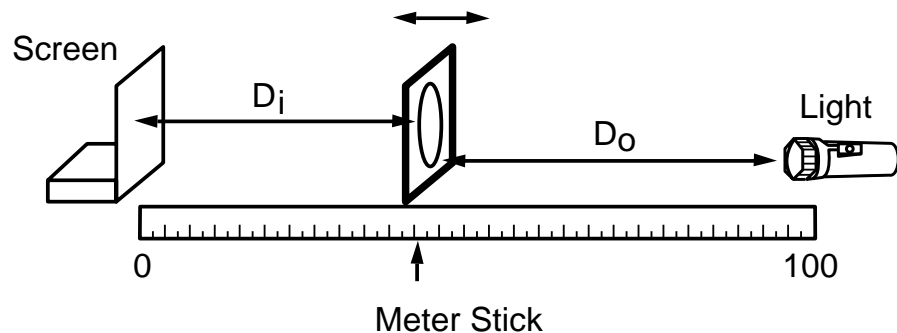

3. If you found two clear images, what was different about them? Why were there two images? (optional)

Which may be written as:

$$f = \frac{D_i D_o}{D_i + D_o}$$

4. Using the following equation, calculate the focal length of each lens using the measurements that you have just made.

Use this equation twice, once for each lens.

$$f_1 = \frac{D_i \times D_o}{D_i + D_o}$$

The following equation describes how the object distance, the image distance, and the focal length are related for a lens.

Focal length lens No. 1 _____ centimeters (cm)

f = focal length
 D_o = object distance
 D_i = image distance

$$f_2 = \frac{D_i \times D_o}{D_i + D_o}$$

$$\frac{1}{f} = \frac{1}{D_o} + \frac{1}{D_i}$$

Focal length lens No. 2 _____ centimeters (cm)

Math Computation:

