

Making a Periscope

Objective

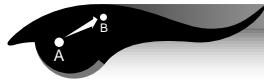

The student will experiment with a simple periscope to see how it reflects light.

Theory



A periscope is an optical instrument that uses a system of prisms, lenses, or mirrors to reflect images through a tube. Light from a distant object strikes the top mirror and is then reflected at an angle of 90 degrees down the periscope tube. At the bottom of the periscope, the light strikes another mirror and is then reflected into the viewer's eye. This simple periscope uses only flat mirrors as compared to the periscopes used on submarines, which are usually a complex optical system using both lenses and mirrors.

Science and Mathematics Standards



Science Standards

- Science as Inquiry
- Physical Science

Mathematics Standards

- Problem Solving
- Communication
- Connection
- Computation/Estimation
- Measurement

Materials



- 2 flat mirrors
- a cardboard tube with openings on each end
- wooden supports
- tape



Procedures



Insert both flat mirrors into the periscope viewing tube as shown. The mirrors must be facing each other. When the mirrors are inserted correctly each mirror will be resting on the wooden supports. As each mirror is inserted, place a small piece of Scotch tape over the mirror slots on the outside of the viewing tube. Hold the periscope so the mirrors are resting on the wooden supports, then look through it.

NOTE: The mirrors will fall out if you turn your periscope upside down.

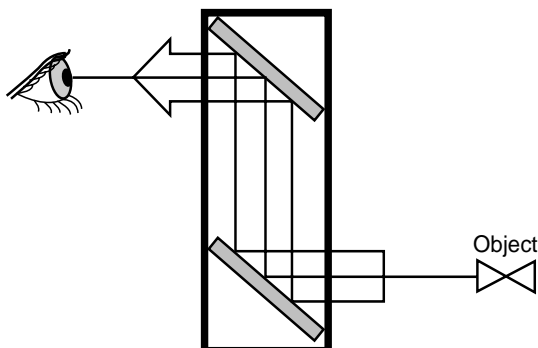

Observations, Data, and Conclusions



1. Draw a diagram of the path a ray of light follows as it travels from an object, through the periscope, and into your eye.
2. Do you think the periscope would work if the mirrors were at some angle other than 45 degrees?

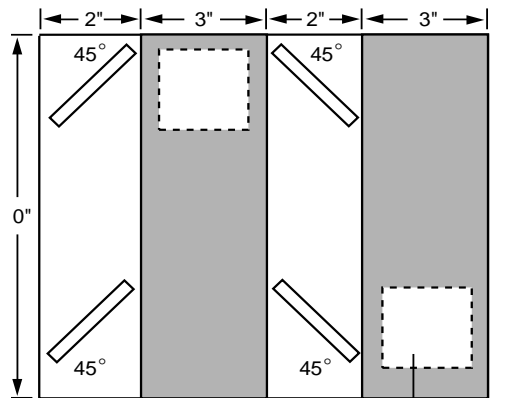

Cut-out square of cardboard

Junior Home Scientist



A periscope can easily be made from materials that you can find at home. The drawing above gives you an example to use. Mirrors of any size will do, as long as they are flat.

