

## Crystallization Model

### Objective:

- To demonstrate how atoms in a solid arrange themselves.

### Science Standards:

- Science as Inquiry  
Physical Science  
- position and motion of objects  
Unifying Concepts & Processes  
Change, Constancy, &  
Measurement  
Science & Technology  
- abilities of technological design

### Science Process Skills:

- Observing  
Communicating  
Collecting Data  
Inferring  
Predicting  
Interpreting Data  
Hypothesizing  
Controlling Variables  
Investigating

### Activity Management:

The crystal model device described here is best suited for use as a classroom demonstration. It is a vibrating platform that illustrates in two dimensions the development of crystal structure and defect formation. BBs, representing atoms of one kind, are placed into a shallow pan which is vibrated at different speeds. The amount of vibration at any one time represents the heat energy contained in the atoms. Increasing the vibration rate simulates heating of a solid material.

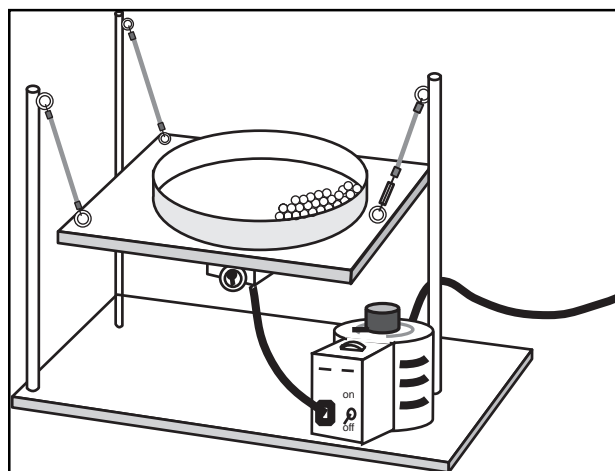

BBs on a vibrating platform arrange themselves in patterns similar to the atoms in solids.

### MATERIALS AND TOOLS

- Wood base and supports
- Shallow pan
- 3 Small bungee cords
- Small turnbuckle
- Surplus 1 10 volt AC electric motor
- Motor shaft collar
- Variable power transformer
- Several hundred BBs
- Hook and loop tape

Eventually, the atoms begin to separate and move chaotically. This simulates melting. Reducing the amount of vibration brings the atoms back together where they “bond” with each other. In this demonstration, gravity pulls the BBs together to simulate chemical bonds. By observing the movement of BBs, a number of crystal defects can be studied as they form and transform. Because of movements in the pan, defects can combine (annihilation) in such a way that the ideal hexagonal structure is achieved and new defects form.



The model is viewed best with small groups of students standing around the device. After the solid “melts,” diminish the motor speed gradually to see the ways the atoms organize themselves. It is important that the platform be adjusted so it is slightly out of level. That way, as the motor speed diminishes the BBs will move to the low side of the pan and begin organizing themselves. If this does not happen, apply light finger pressure to one side of the pan to lower it slightly. This will not affect the vibration movements significantly. While doing the demonstration, also stop the vibration suddenly. This will simulate what happens when molten material is quenched (cooled rapidly) .

The motor collar required in the materials list is available from a hardware store. The purpose of the collar is to provide an offcenter weight to the shaft of the motor. The set screw in the collar may have to be replaced with a longer one so that it reaches the motor shaft for proper tightening.

## Constructing The Vibrating Platform

Note: Specific sizes and part descriptions have not been provided in the materials list because they will depend upon the dimensions of the surplus electric motor obtained. The motor should be capable of several hundred revolutions per minute.

1. Mount three vertical supports on to the wooden base. They can be attached with corner braces or by some other means.
2. Mount the surplus motor to the bottom of the vibrating platform. The specific mounting technique will depend upon the motor. Some motors will feature mounting screws. Otherwise, the motor may have to be mounted with some sort of strap. When mounting, the shaft of the motor should be aligned parallel to the bottom of the platform.
3. Slip the collar over the shaft of the motor and tighten the mounting screw to the shaft. See the diagram below for how the shaft and collar

should look when the collar is attached properly.

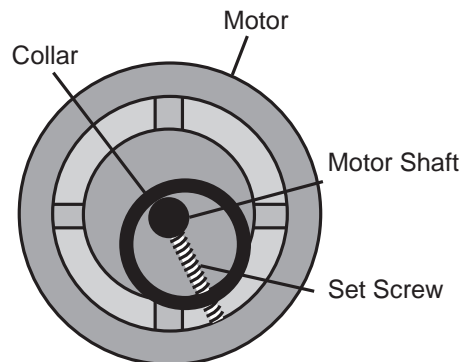

4. Suspend the platform from the three vertical supports with elastic shock (bungee) cords or springs. Add a turnbuckle to one of the cords for length adjustment. Shorten that cord an amount equal to the length of the turnbuckle so the platform hangs approximately level.
5. Using hook and loop tape, mount the pan on the upper side of the vibrating platform.
6. Place several hundred BBs in the pan. If the BBs spread out evenly over the pan, lengthen the turnbuckle slightly so the BBs tend to accumulate along one side of the pan.
7. Turn on the motor by raising the voltage on the variable transformer. If the device is adjusted properly, the BBs will start dancing in the pan in a representation of melting. Lower the voltage slowly. The BBs will slow down and begin to arrange themselves in a tight hexagonal pattern. If you do not observe this effect, adjust the leveling of the platform slightly until you do. It may also be helpful to adjust the position of the motor slightly.

## Conducting The Experiment

1. Turn up the voltage on the variable transformer until the BBs are dancing about in the pan. This represents melting of a solid.
2. Shut the variable transformer off. This represents rapid cooling of the liquid to a glassy (amorphous) state. Observe and sketch the pattern of the BBs and of the defects.
3. Turn up the voltage again and gradually reduce the vibration until the BBs are moving slowly. Observe how the BBs move and pack together.

## Assessment:

Collect the student work sheets.

## Extensions:

1. Obtain some mineral crystal samples and examine them for defects. Most crystals will have some visible defects. The defects will be at a much larger scale than those illustrated in the student reader. One defect that is easy to find in the mineral quartz is color variations due to the presence of impurities.
2. Investigate the topic of impurities deliberately incorporated in crystals used to manufacture computer chips. What do these defects do?
3. Design a crystal-growing experiment that could be used on the International Space Station. Conduct a ground-based version of that experiment. How would the experiment apparatus have to be changed to work on the space station?



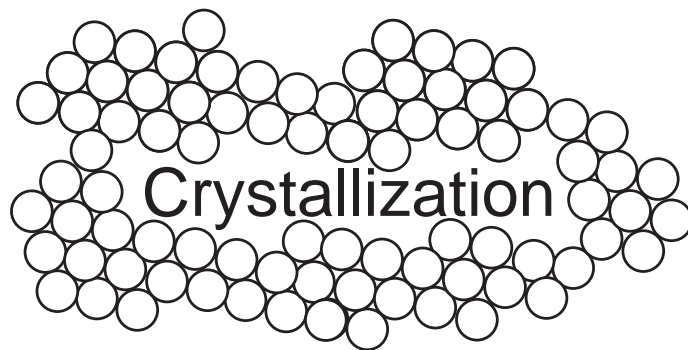

Crystalline solids are substances whose atoms or molecules are arranged into a fixed pattern that repeats in three dimensions. Crystalline materials generally begin as a fluid of atoms or molecules in either the liquid or gaseous state. As they change to the solid state, the atoms or molecules join together in repeating patterns. Materials that do not form these patterns are called amorphous. Glass is a good example of an amorphous material.

The usefulness of a crystal depends on its structure. All crystalline materials have varying degrees of defects. Defects can take many forms. Gem-quality diamonds sometimes have small inclusions of carbon (carbon spots) that diminish their light refraction and thereby reduce their value. In other crystalline materials, defects may actually enhance value. Crystals used for solid state electronics have impurities deliberately introduced into their structure that are used to control their electrical properties. Impurity atoms may substitute for the normal atoms in a crystal's structure or may fit in the spaces within the structure. Other defects include vacancies, where atoms are simply missing from the structure, and dislocations, in which a half plane of atoms is missing. The important thing about crystal defects is to be able to control their number and distribution. Uncontrolled defects can result in unreliable electronic properties or weaknesses in structural metals.

### Sample Crystal Defects

The following diagrams show a magnified view of an ideal two-dimensional crystalline structure (hexagonal geometry) and a variety of defects that the structure might have.

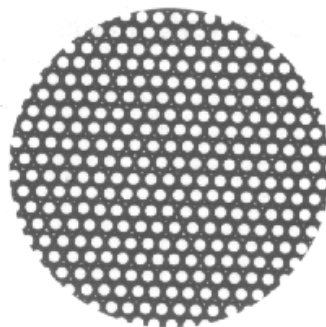

Ideal crystalline structure

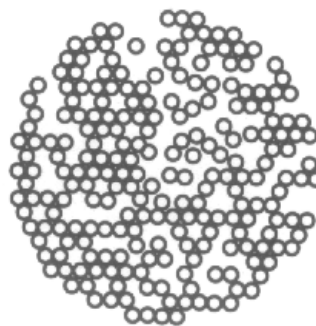

Amorphous or glassy structure (when stationary) or a liquid structure (when in motion)

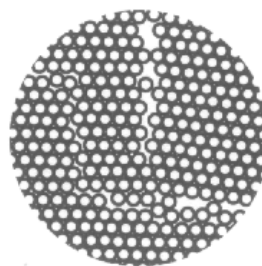

Crystalline structure with surface (grain boundary) defect

Many forces can affect the structure of a crystal. One of the most important forces that can influence the structure of a growing crystal is gravity. Growing crystals in microgravity can reduce gravity effects to produce crystals with better defined properties. The information gained by microgravity experiments can lead to improved crystal processing on Earth.

The connection between the force of gravity and the formation of defects varies from very simple and straightforward to complicated and nonintuitive. For example, mercury iodide crystals can form from the vapor phase. However, at the growth temperature (approximately 125° C) the crystal structure is so weak that defects can form just due to the weight of the crystal. On the other hand, the relationship between residual fluid flows caused by gravity and any resulting crystalline defects is not well understood and may be very complex.

Crystalline structure with point defects (vacancies and substitution impurities)

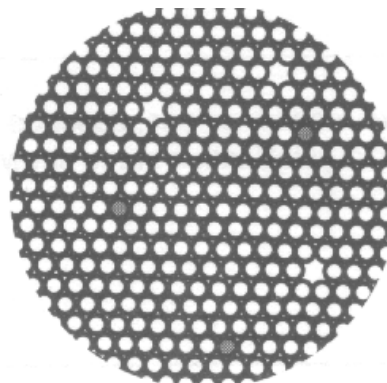

Crystalline structure (further magnified) with interstitial defect and edge dislocations

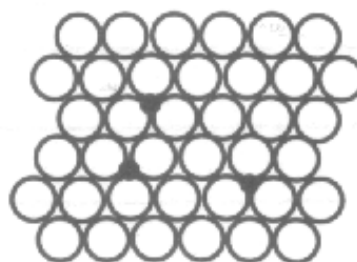

- Interstitial -

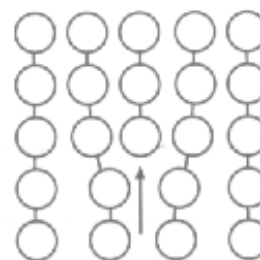

- Edge

# Crystallization

Name: \_\_\_\_\_

Based on your observations, describe and sketch each crystallization stage shown with the model.

Melting:

---

---

---

---

---

---

---

---

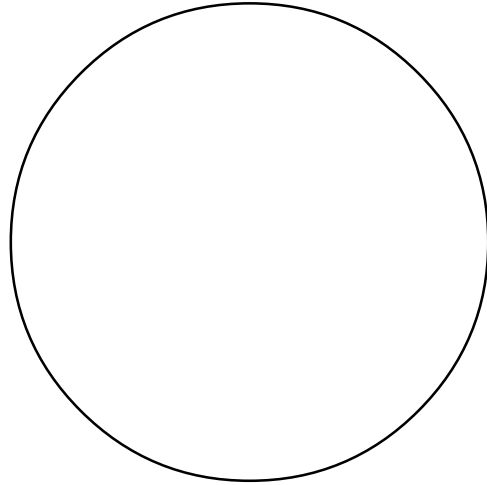

Fast Cooling:

---

---

---

---

---

---

---

---

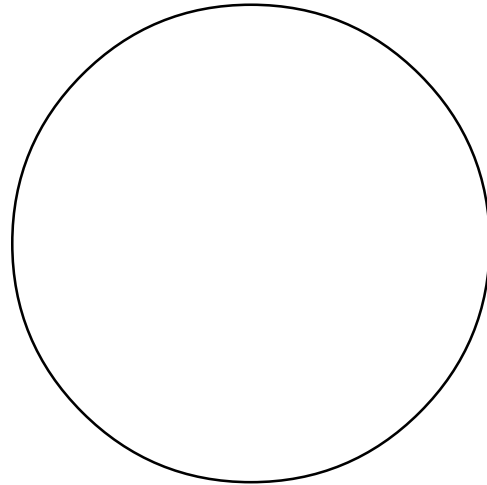

Slow Cooling:

---

---

---

---

---

---

---

---

