

Unit 2



Learning from Apollo

The Lunar Disk
Apollo Landing Sites
Regolith Formation
Lunar Surface
Differentiation
Impact Craters
Clay Lava Flows
Lava Layering
Lunar Landing Sites
Lunar Roving Vehicle
Moon Anomalies

The U.S. Space Program called Apollo achieved monumental goals including the collection and return of rock and sediment samples from the Moon. Analyses of the samples by scientists worldwide continue to give us new insight to the forces that shaped the early solar system, the Moon, and maybe most importantly, Earth. This excitement of discovery, a legacy of the Apollo program, is the theme of Unit 2.

The highlight of this unit is the Lunar Sample Disk. Classroom activities focus on the Moon's rocks, surface features, and the geologic processes that formed them. Students are then given the opportunity to plan their own lunar missions in the “Lunar Landing Sites” and “Lunar Roving Vehicle” activities. The last activity of the unit presents four anomalies of the Moon for investigation and interpretation.

A Resource Section for Unit 2 is on Page 38.

Unit 2

Resource Section

This list presents possible independent and commercial sources of items to complement the activities in Unit 2. The sources are offered without recommendation or endorsement by NASA. Materials from the U.S. Government Printing Office also are included. Inquiries should be made directly to the appropriate source to determine availability, cost, and ordering information before sending money. Contact your NASA Educator Resource Center (see Page 146) for more resources available directly from NASA.

Books

Apollo Over the Moon: A View From Orbit, NASA SP-362, 1978, 255 p. Annotated picture book of lunar geologic features. U.S. Government Printing Office, Superintendent of Documents
P.O. Box 371954
Pittsburgh, PA 15250-7054
phone 1-202-783-3238

Apollo Expeditions to the Moon, NASA SP-250, 1975, 313 p. Illustrated chronicle of the Apollo missions with a focus on the engineering and teamwork that made the missions possible.
U.S. Government Printing Office, same as above.

The Moon, by Patrick Moore, 1981, Rand McNally and Co., 96 p. Illustrated with maps, drawings, and Apollo mission photographs. Also gives descriptions of unmanned missions including Russian Luna probes.

To Rise From Earth: An Easy to Understand Guide to Space Flight, by Wayne Lee, 1993, Texas Space Grant Consortium (ISBN 0-9637400-3-2), 279 p. Detailed, non-mathematical discussions of orbital mechanics, Apollo missions, and the Shuttle.

To A Rocky Moon: A Geologist's History of Lunar Exploration, by Don E. Wilhelms, 1993, Univ. of Arizona Press, 477 p.

Carrying the Fire: An Astronaut's Journeys, by Michael Collins, 1974, Ballantine Books, 488p. p.

Apollo and the Moon Landing, by Gregory Vogt, 1991, Millbrook Press, 112 p. An illustrated text in the Missions in Space Series for grades 4-6.

Slides

The Apollo Landing Sites, set of 40 slides
Lunar and Planetary Institute
3600 Bay Area Boulevard
Houston, TX 77058-1113
phone 1-281-486-2172 or fax 1-281-486-2186

Videos

Out of This World: The Apollo Moon Landings, Finley-Holiday Film Corp./Steve Skootsky, 1993, 60 minutes. Historically accurate video using newly restored NASA footage. Finley-Holiday Film Corp.
P.O. Box 619
Whittier, CA 90608
phone 1-800-345-6707

Rockets and Models

Estes Industries
P.O. Box 227
Penrose, CO 81240

Other Teacher's Guides

Exploring Meteorite Mysteries: Teacher's Guide with Activities, NASA EG-1997-08-104-HQ.
Marilyn Lindstrom et. al., 1997.

Rockets: Physical Science Teacher's Guide with Activities, NASA EP-291.
Gregory L. Vogt, 1993.



The Lunar Disk

Purpose

To carefully look at, describe, and learn about the origins of the six lunar samples contained in the disk.

Background [also see "Teacher's Guide" Pages 1, 4-9, photo on 15, 16 and "About the Lunar Sample Disk" on Page iv]

The six **Apollo** missions that landed **astronauts** on the Moon returned a collection of **rocks** and **sediment** samples weighing 382 kilograms and consisting of more than 2,000 separate samples.

Each lunar disk contains six small samples of lunar material. Descriptions of the samples accompany every disk; included are annotated color photographs, discussion of origins, and Apollo missions and collection sites.

Preparation

First, do the "Reaping Rocks" activity on Page 33 or spend time on a basic unit on rock and mineral identification.

Read the rock descriptions provided with the Lunar Sample Disk.

Review and prepare materials listed on the student sheet.

Each student will need two copies of the "Lunar Disk Sample Chart," there is room for three samples per page. Use of magnifying lenses or a stereo microscope would greatly enhance observations.

Have on hand the students' "My Own Rock Charts" for comparisons to the lunar samples. You may also want to collect some sediment from the school yard to display on a glass slide. Students could then compare this sediment to the lunar samples. Most likely, evidence of life will be seen in the school yard sediment under magnification, including plant matter, bits of plastic, fibers, etc.

In Class

The Lunar Sample Disk is a national treasure and students need to be reminded about the proper way to handle it. The disk must be in your sight during use.

Encourage students to describe the samples with as many adjectives or descriptive phrases as possible. The "Lunar Disk Sample Chart" will help students organize their observations and interpretations.

The Lunar Disk

Note: The name of each sample is labeled on the disk and may be entered on the chart under *classification*. The sediment samples, instead of being labeled regolith, are labeled "soil." Remind the students this is a misnomer because there are no organic materials in lunar regolith.

Ask the students if their predictions of the Moon rocks were accurate.

Wrap-Up

By comparing the lunar samples with their own rock collections, students can discuss the similarities and differences between Earth and Moon rocks. Discuss the various ways that rocks are formed on Earth and the Moon.



The Lunar Disk

Purpose

To carefully look at, describe, and learn about the origins of the six lunar samples contained in the disk.

Key Words

anorthosite
mare basalt
orange "soil"
breccia
mare "soil"
highland "soil"

Materials

Lunar Disk
magnifying lens or stereo microscope
"Lunar Disk Sample Chart"
"My Own Rock Chart"
"Moon ABCs Fact Sheet"

Caution

The only way to handle the Lunar Sample Disk is with care.

Always place it on the soft cloth to prevent scratches to the surface. The disk must always be in the teacher's sight.

Care for and enjoy this national treasure.

Procedure

1. Look at each **lunar sample** with and without a **magnifying lens or stereo microscope**.
What details can you see under magnification?
2. Describe what you see by filling out "**Lunar Disk Sample Chart**." Use as many adjectives or descriptive phrases as you can.
3. Do the Moon rocks look like what you expected?

4. Which lunar samples closely resemble rocks from your collection?

5. Based on your comparisons of Earth and Moon rocks, what can you now say about the origins of the lunar samples contained in the disk? Add this information to your chart.

6. Which rock types on Earth are not found in the lunar samples? Why?

Lunar Disk Sample Chart

Interpretations		Observations					
		Sketch of Sample					
Origin	Classification	Apollo Mission/ Collection Site	Texture	Colors	Size	Shape	



Apollo Landing Sites

Purpose

To learn about the locations and geology of the six Apollo landing sites.

Background

Latitude and **longitude** coordinates for the Moon start at a point near the crater Bruce. From this starting point (0° latitude, 0° longitude) locations towards the east side of the Moon (the direction in which the sun rises) are indicated with east longitude values. Locations towards the west side (the direction in which the sun sets) have west longitude values. North latitude is measured towards the Moon's north pole. South latitude is measured towards the Moon's south pole.

Twelve **astronauts** in six **Apollo** missions landed on and explored the **nearside** (Earth-facing side) of the Moon between 1969 and 1972. The six landing sites were chosen to explore different geologic **terrains**.

Refer to the rock descriptions included with the Lunar Sample Disk for details on where the samples came from and who collected them. An answer chart is provided.

Preparation

Review and prepare materials listed on the student sheet.
See the Resource Section on Page 24 for sources of maps and globes.

In Class

Refer back to the Lunar Sample Disk to review the collection sites of each sample. Ask students to consider the geologic differences of the six sites.

Wrap-up

Were the Apollo landing sites in similar terrains? Which crew was the first to work in hilly terrain?

Extensions

1. Form cooperative teams to research each Apollo landing site (the who, what, when, where, and why) and to report to the class.
2. Why were all six Apollo landing sites on the nearside of the Moon?
3. Why were there no further Apollo Moon landings?
4. Was Apollo the only program to land on the Moon? Discuss the unpiloted American and Soviet missions and landings.

Apollo Landing Sites Chart

Apollo Mission	Landing Date	Longitude	Latitude	Major Geologic Features and Rock Types (rock types underlined are found in the Lunar Sample Disk)
11	July 20, 1969	23 °E	1 °N	Mare (Sea of Tranquility), basaltic lava.
12	Nov. 19, 1969	23 °W	3 °S	Mare (Ocean of Storms), rocks are basaltic lava; ray from Copernicus Crater crosses the site.
14	Jan. 31, 1971	17 °W	3 °S	Highlands (Fra Mauro formation) - thought to be ejecta from the Imbrium Basin.
15	July 30, 1971	4 °E	26 °N	Mare (Hadley Rille in a mare area near the margin of Mare Imbrium) and highlands (Apennine Mountains, a ring of the Imbrium basin); rocks are <u>breccia</u> and <u>basalt</u> .
16	April 21, 1972	16 °E	9 °S	Highlands (Descartes formation and Cayley Plains); rocks are <u>anorthosite</u> and <u>highlands soil</u> .
17	Dec. 11, 1972	31 °E	20 °N	Mare (Sea of Serenity) and Highlands; rocks are <u>mare soil</u> , <u>orange soil</u> , <u>basaltic lava</u> , <u>anorthosite</u> .



Apollo Landing Sites

Purpose

To learn about the locations and geology of the six Apollo landing sites.

Key Words

latitude

longitude

mare

highlands

Sea of Tranquility

Ocean of Storms

Fra Mauro

Hadley-Appenine

Descartes

Sea of Serenity

Taurus-Littrow

Materials

lunar maps with latitude and longitude grid

“Apollo Landing Sites Chart”

Moon globe

Procedure

1. Look at a **map** of the Moon showing the Apollo landing sites. Fill in the “**Apollo Landing Sites Chart.**”

2. Find the landing sites on a **globe** of the Moon.

3. How do **latitude** and **longitude** compare on Earth and on the Moon?

4. Compare and contrast the six Apollo landing sites. (Think about who, when, where, and geology for your answer.)

5. Which site would you most like to visit? Why?

Apollo Landing Sites Chart

Apollo Mission	Landing Date	Longitude	Latitude	Major Geologic Features and Rock Types



Regolith Formation

Purpose

To compare the process of regolith formation on Earth and on the Moon.

Background [also see “Teacher's Guide” Pages 4, 5]

The loose, fragmental material on the Moon's surface is called **regolith**. This regolith, a product of **meteoritic bombardment**, is the debris thrown out of the **impact craters**. The composition and texture of the lunar regolith varies from place to place depending on the **rock** types impacted.

Generally, the older the surface, the thicker the regolith. The regolith on young **maria** may be only 2 meters thick; whereas, it is perhaps 20 meters thick in the older lunar **highlands**.

By contrast, regolith on Earth is a product of **weathering**. Weathering encompasses all the processes that cause rocks to fragment, crack, crumble, or decay. These processes can be *physical* (such as freezing water causing rocks to crack), *chemical* (such as decaying of minerals in water or acids), and *biological* (such as plant roots widening cracks in rocks).

The rock debris caused by weathering can then be loosened and carried away by **erosional** agents -- *running water* (fast-flowing rivers, rain, ocean waves), *high-speed wind* (by itself or sandblasting), and *ice* (glaciers).

In this activity, procedures A and B challenge the students to determine the effects of wind, sandblasting, and water on regolith formation and deposition on Earth. This is followed by procedure C in which the students simulate regolith formation on the Moon by meteoritic bombardment.

Preparation

Review and prepare materials listed on the student sheet.

Toast, crackers, or brittle cookies can be used in this activity. Toast is the least expensive but most time consuming choice. In any case, students will need two different colors of materials for procedure C; for example, vanilla and chocolate graham crackers. Invariably, students get hungry at the sight of food, so you may want to reserve some clean materials for consumption or use something other than a rock for the projectile.

To prepare bread: use a conventional oven, toaster, or sun-dry method to produce the most crisp and brittle toast. Toast one loaf of white bread and one loaf of golden wheat or rye bread. Note that whole wheat bread does not get brittle enough.

Regolith Formation

For procedure B, fill margarine containers (one for each group) with water and sand, then freeze. The more sand, the better the illusion to a real rock.

For procedure C, do not use glass pans. Large plastic tubs are preferred for this procedure, but recyclable aluminum roasting pans or shallow cardboard boxes work as well.

In Class

Divide the students into cooperative groups and distribute materials.

Discuss the definition of regolith. Have students guess how regolith is formed on Earth and on the Moon. Ask students for justification.

If sand paper or nail files are not available, then students can use the edge of a ruler to illustrate the effects of sandblasting in procedure A. Caution students to use a collection tray in the sink in procedure B to avoid sand-clogged drains. An alternative to using a faucet is to have the students pour a steady stream of water from beakers onto their ice-cube rocks to illustrate the effects of falling water.

Have students guess individually, then discuss in groups, what the surface of the Moon is like (hard rocks, fine dust, large boulders). Ask students for justification of their answers.

Refer to a photograph of an astronaut's footprint on the surface of the Moon. Give students the opportunity to change or confirm their guesses.

Procedure C is best done outside. Drop the rock from waist high. Sometimes the impacting rock causes the pan to bounce so you may want to secure the pan to the ground with tape. Students should stand back as a safety precaution.

Wrap-up

After participating in the activity, have the whole class compare and contrast regolith formation and ask each small group to verify their original guesses.



Regolith Formation

Purpose

To compare and contrast the process of regolith formation on Earth and on the Moon.

Key Words

regolith
meteoritic bombardment
weathering
erosion

Materials

toasted white bread
toasted golden wheat bread
small pan
sand paper, nail file, or edge of ruler
ice cube with sand inside
tray
fist-size rock

Regolith formation on Earth

Procedure A

What effect does wind have on regolith formation?

1. Imagine that the piece of toasted bread is a rock on Earth. Your hand is the wind. The sand paper is wind carrying particles of sand.
2. Predict the effects of rubbing just your hand and then the sand paper across the toasted bread.

3. Now try it. Rub your hand across the **toasted bread** and observe the bread and the pieces which fall from it onto the **pan**. Observations:

4. This time rub the **sand paper** across the toasted bread and observe the bread and the pieces which fall from it onto the pan. Observations:

Regolith Formation

5. How was the effect different?

6. How is this activity related to processes on Earth?

Procedure B

What effect does falling or fast flowing water have on regolith formation?

1. Imagine that the **ice cube with sand** is a rock.
2. Place this ice cube on a collection tray beneath the **water faucet**.
3. Adjust the water flow from the faucet so a medium stream hits the ice cube.
4. Observe what happens to the ice cube and the remaining particles.
5. What happened to the rock (ice cube)?

6. Describe the particles which remain.

Regolith Formation

7. How does water contribute to regolith formation on Earth?

Regolith formation on the Moon

Procedure C

1. Do you think regolith on the Moon is formed in the same manner as on Earth? Why or why not?

Now we will investigate the effects of meteoritic bombardment on regolith formation.

2. In a small **pan**, place 2 slices of **toasted white bread** onto 3 slices of **toasted golden wheat bread**. This represents the Moon's crust.

3. Drop a **rock** onto the layers of toasted bread twice. Describe the bread slices and the crumbs.



Lunar Surface

Purpose

To make a model of the Moon's surface and to consider the geologic processes and rocks of each area.

Background [also see “Teacher's Guide” Pages 2, 3, 4, 12, 13]

A variety of features are evident on the lunar surface. These features include **craters** with and without **rays** (also see the “Impact Craters” activity on Page 61), **crater chains**, **maria**, **rilles**, and **mountains**.

crater chains - in curved paths are probably incompletely formed rilles,

- in straight paths are probably from rocks thrown out during an impact event and landing in a row.

rilles

- are long valleys crossing maria that formed as underground lava channels which collapsed after the hot lava flowed away.

mountains

- almost all in the highlands are the rims of large craters,

- also occur in the centers of craters that are larger than 40 km diameter; these mountains are called central uplifts,

- also occur as low, circular, rounded hills called domes.

In this activity students will use clay, plaster of Paris, or playdough to construct model surfaces to match what they see on maps and photographs of the Moon. They “flag” Apollo landing sites and consider the collection site of each Lunar Disk sample.

Preparation

Review and prepare materials listed on the student sheet.

Obtain one or more lunar maps. Students can either be assigned to or given a choice of specific areas to model. Using maps of both the nearside (Earth-facing side) and farside of the Moon will give more variety of surface features.

Collect trays or shallow cardboard boxes and modeling material (recipes for playdough appear on Page 78). Assemble sculpturing tools such as wooden sticks, plastic knives, rolling pins, etc.

Lunar Surface

It is beneficial to do “The Lunar Disk” activity (on Page 39) first so students can relate the samples to their model surfaces.

In Class

Consider having cooperative teams build one model surface. Each team is responsible for describing the surface features, explaining the geology, and listing the typical rock types of the area. Either draw an outline around each area on a Moon map or if you have an extra map, cut the map into sections. The whole map is finally recreated by putting the model surfaces back together.

Have the students use toothpick flags to label Apollo landing sites.

Wrap-up

Review the variety of surface features found on the Moon. Are some features more common than others?

What are the most common terrains on the Moon? Do these terrains exist on the nearside, farside, or globally?

Review the processes that made the various surface features. Also see the “Impact Craters” activity on Page 61 and the “Clay Lava Flows” activity on page 71.

What kinds of rocks are found in the areas modeled by the students? Also see the “Apollo Landing Sites” activity on page 43 and the literature which accompanies the Lunar Sample Disk.

If the student teams made models of different sections of a large map, then did the modeled surface features match from tray to adjacent tray? Have the students discuss why or why not.



Lunar Surface

Purpose

To make a model of the Moon's surface and to consider the geologic processes and rocks of each area.

Key Words

crater
mountain
rille
mare
crater chain
ray
terrain

Materials

binoculars or telescope
lunar map
photographs of the Moon
clay, plaster of Paris, or playdough
tray
sculpturing tools
toothpick flags
Lunar Sample Disk

Procedure

1. Observe the Moon using **binoculars** or a **telescope**. What surface features can you see?

2. Look at a **map** and **photographs** of the Moon. List the many different features you see.

3. Prepare a model lunar surface by placing a thin, even layer of **modeling material** on a **tray**.
4. Use **sculpturing tools** to form the features that you see on the Moon's surface.

Lunar Surface

5. How do you think these surface features were created on the Moon? List at least one idea for each kind of feature.

11

6. If your model surface has an Apollo landing site, then label it with a **toothpick flag**.

7. What kinds of rocks occur in your area? If your area has an Apollo landing site, then include the names of samples from the **Lunar Sample Disk** in your answer.

8. Compare your model surface with your classmates' surfaces. Can you match features from one area to another? Why or why not?



Differentiation

Purpose

To see how minerals separate from each other in a magma ocean.

Background [also see “Teacher’s Guide” Page 12]

When planets begin to melt, the materials in them begin to separate from one another. The heaviest materials, such as metallic iron, sink to form **cores**. Low density magmas rise forming **crusts**. This process is called **differentiation**.

Soon after formation, the Moon melted substantially forming a large body of **magma** that completely surrounded it. This is called the **lunar magma ocean**. The main evidence that this actually happened on the Moon is the presence of large amounts of the **mineral plagioclase feldspar** in the ancient, lunar **highlands** crust. Scientists surmise feldspar floated in the magma ocean and accumulated at the top, while denser minerals such as olivine and pyroxene sank and accumulated at the base of the magma ocean.

This same process happens in lava lakes and in magma chambers beneath **volcanoes** on Earth. Minerals denser than the melt sink; those less dense float. It is an important geological process that leads to the production of a wide variety of **igneous rocks**.

Preparation

Review and prepare materials listed on the student sheet. Students will simulate the process of differentiation using readily-available materials: water, a transparent container (1000-milliliter beakers are good because they look scientific, but any wide-mouthed glass will work), pennies or metal shot, sand, and toothpicks.

In Class

Take a handful of pennies, sand, and toothpicks and dump them into the water. The pennies (or metal shot) sink faster than the sand. The toothpicks float. The floating toothpicks lie at a variety of angles and are analogous to the feldspar that formed the initial lunar crust. There ought to be more pennies than sand on the very bottom, with sand on top of that pile. (The pennies are much denser, 8.9 grams per cubic centimeter, than the sand, about 2.6 grams per cubic centimeter, so the pennies sink faster.) The clear water in between represents still-molten magma.

Differentiation

This activity can be done as a demonstration if you prefer.

Wrap-up

Relate the sinking and floating objects to the differentiation of the Moon's magma ocean.



Differentiation

Purpose

To see how minerals separate from each other in a magma ocean.

Key Words

differentiation
density
magma ocean

Materials

pennies
sand
toothpicks
bowl
transparent container
water

Procedure

1. Mix the **pennies, sand, and toothpicks** in the **bowl**.
2. Fill the **container** with **water** to about 2 cm from the top.
3. Predict what will happen when you drop a handful of the pennies-sand-toothpicks mixture into the water. Will they all sink to the bottom? Will some sink faster than others?

4. Now drop the mixture into the water. Wait until the objects stop moving and look at the deposits. What do you see?

Differentiation

5. Can you explain what causes the differences in the way the objects sink or float?

6. Suppose the mineral feldspar in the lunar magma ocean responded like the toothpicks in the water. What does this tell you about the formation of the original crust on the Moon?

7. What makes up the highlands of the Moon? Based on this experiment, does this make sense?

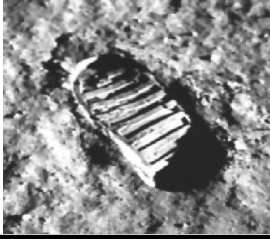

Impact Craters

Purpose

To determine the factors affecting the appearance of impact craters and ejecta.

Background [also see “Teacher's Guide” Pages 1, 2, photo on 8, 12, and photo on 13]

The circular features so obvious on the Moon’s surface are **impact craters** formed when **impactors** smashed into the surface. The explosion and excavation of materials at the impacted site created piles of rock (called **ejecta**) around the circular hole as well as bright streaks of target material (called **rays**) thrown for great distances.

Two basic methods forming craters in nature are:

1) impact of a **projectile** on the surface and 2) collapse of the top of a **volcano** creating a crater termed *caldera*. By studying all types of craters on Earth and by creating impact craters in experimental laboratories geologists concluded that the Moon's craters are impact in origin.

The factors affecting the appearance of impact craters and ejecta are the size and velocity of the impactor, and the geology of the target surface.

By recording the number, size, and extent of erosion of craters, **lunar geologists** can determine the ages of different surface units on the Moon and can piece together the geologic history. This technique works because older surfaces are exposed to impacting **meteorites** for a longer period of time than are younger surfaces.

Impact craters are not unique to the Moon. They are found on all the terrestrial planets and on many moons of the outer planets.

On Earth, impact craters are not as easily recognized because of weathering and erosion. Famous impact craters on Earth are Meteor Crater in Arizona, U.S.A.; Manicouagan in Quebec, Canada; Sudbury in Ontario, Canada; Ries Crater in Germany, and Chicxulub on the Yucatan coast in Mexico. Chicxulub is considered by most scientists as the source crater of the catastrophe that led to the extinction of the dinosaurs at the end of the Cretaceous period. An interesting fact about the Chicxulub crater is that you cannot see it. Its circular structure is nearly a kilometer below the surface and was originally identified from magnetic and gravity data.

Aristarchus

Typical characteristics of a lunar impact crater are labeled on this photograph of Aristarchus, 42 km in diameter, located West of Mare Imbrium.

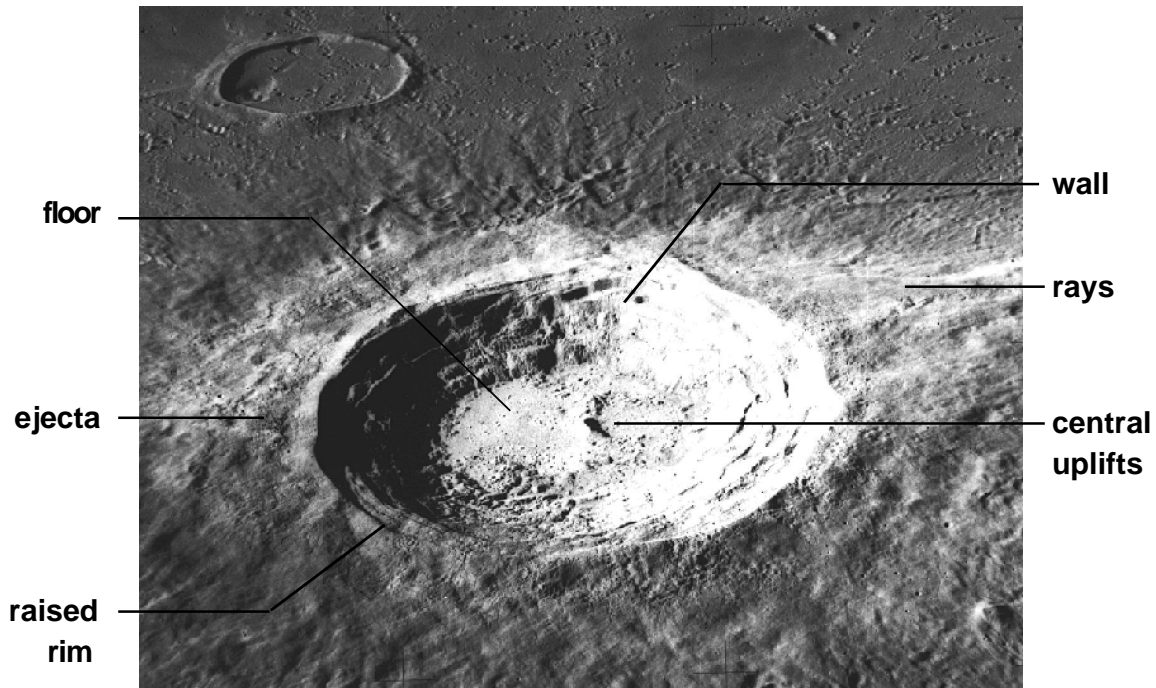

- raised rim** - rock thrown out of the crater and deposited as a ring-shaped pile of debris at the crater's edge during the explosion and excavation of an impact event.
- floor** - bowl shaped or flat, characteristically below surrounding ground level unless filled in with lava.
- central uplifts** - mountains formed because of the huge increase and rapid decrease in pressure during the impact event. They occur only in the center of craters that are larger than 40 km diameter. See Tycho crater for another example.
- walls** - characteristically steep and may have giant stairs called terraces.
- ejecta** - blanket of material surrounding the crater that was excavated during the impact event. Ejecta becomes thinner away from the crater.
- rays** - bright streaks starting from a crater and extending away for great distances. See Copernicus crater for another example.

Impact Craters

Preparation

Review and prepare materials listed on the student sheet.

In this activity, marbles or other spheres such as steel shot, ball bearings, golf, or wooden balls are used as impactors dropped from a series of heights onto a prepared “lunar surface.” Using impactors of different mass dropped from the same height will allow students to study the relationship of mass of the impactor to crater size. Dropping impactors from different heights will allow students to study the relationship of velocity of the impactor to crater size.

The following materials work well as a base for the “lunar surface” topped with a dusting of dry tempera paint or other material in a contrasting color:

- all purpose flour - Reusable in this activity and keeps well in a covered container.
- baking soda - It can be recycled for use in the lava layer activity or for many other science activities. Reusable in this activity, even if colored, by adding a clean layer of new white baking soda on top. Keeps indefinitely in a covered container. Baking soda mixed (1:1) with table salt also works.
- corn meal - Reusable in this activity but probably not recyclable. Keeps only in freezer in airtight container.
- sand and corn starch - Mixed (1:1), sand must be very dry. Keeps only in freezer in airtight container.
- dry tempera paint or powdered drink mixes or glitter - Sift on top; use a sieve, screen, or flour sifter. A contrasting color to the base materials gives striking results.

Pans should be plastic, aluminum, or cardboard. Do not use glass. They should be at least 7.5 cm deep. Basic 10"x12" aluminum pans or plastic tubs work fine, but the larger the better to avoid misses. Also, a larger pan may allow students to drop more marbles before having to resurface the target materials.

A reproducible student “Data Chart” is included; students will need a separate chart for each impactor used in the activity.

In Class

1. Begin by looking at craters in photographs of the Moon and asking students their ideas of how craters formed.
2. During this activity, the flour, baking soda, or dry paint may fall onto the floor and the baking soda may even be disbursed into the air. Spread newspapers under the pan(s) to catch spills or consider doing the activity outside. Under supervision, students have successfully dropped marbles from second-story balconies. Resurface the pan before a high drop.
3. Have the students agree beforehand on the method they will use to “smooth” and resurface the material in the pan between impacts. The material need not be packed down. Shaking or tilting the pan back and forth produces a smooth surface. Then be sure to reapply a fresh dusting of dry tempera paint or other material. Remind students that better experimental control is achieved with consistent handling of the materials. For instance, cratering results may vary if the material is packed down for some trials and not for others.
4. Allow some practice time for dropping marbles and resurfacing the materials in the pan before actually recording data.
5. Because of the low velocity of the marbles compared with the velocity of real impactors, the experimental impact craters may not have raised rims. Central uplifts and terraced walls will be absent.
6. The higher the drop height, the greater the velocity of the marble, so a larger crater will be made and the ejecta will spread out farther.
7. If the impactor were dropped from 6 meters, then the crater would be larger. The students need to extrapolate the graph out far enough to read the predicted crater diameter.

Wrap-Up

Have the class compare and contrast their hypotheses on what things affect the appearance of craters and ejecta.

Impact Craters

Extensions

1. As a grand finale for your students, demonstrate a more forceful impact using a slingshot.
2. What would happen if you change the angle of impact? How could this be tested? Try it! Do the results support your hypothesis?

If the angle of impact is changed, then the rays will be concentrated and longer in the direction of impact. A more horizontal impact angle produces a more skewed crater shape.

3. To focus attention on the rays produced during an impact, place a paper bulls-eye target with a central hole on top of a large, flour-filled pan. Students drop a marble through the hole to measure ray lengths and orientations.
4. Use plaster of Paris or wet sand instead of dry materials.
5. Videotape the activity.
6. Some people think the extinction of the dinosaurs was caused by massive global climate changes because of a meteorite impact on Earth. Summarize the exciting work that has been done at Chicxulub on the Yucatan coast of Mexico.
7. Some people think Earth was hit by an object the size of Mars that caused a large part of Earth to “splash” into space, forming the Moon. Do you agree or disagree? Explain your answer.
8. Physics students could calculate the velocities of the impactors from various heights. (Answers from heights of 30 cm, 60 cm, 90 cm, and 2 m should, of course, agree with the velocity values shown on the “Impact Craters - Data Chart”.

Name: _____

Date: _____

impactor #

gm

Impact Craters - Data Chart

		trial 1	trial 2	trial 3	total	average
drop height = 30 cm velocity = 242 cm/s	crater diameter					
	crater depth					
	average length of all rays					
drop height = 60 cm velocity = 343 cm/s	crater diameter					
	crater depth					
	average length of all rays					
drop height = 90 cm velocity = 420 cm/s	crater diameter					
	crater depth					
	average length of all rays					
drop height = 2 meters velocity = 626 cm/s	crater diameter					
	crater depth					
	average length of all rays					



Impact Craters

Purpose

To determine the factors affecting the appearance of impact craters and ejecta.

Key Words

impact

impactor

ejecta

Materials

1 pan

“lunar” surface material

tempera paint, dry

sieve or sifter

balance

3 impactors (marbles or other spheres)

meter stick

ruler, plastic with middle depression

protractor

“Data Chart” for each impactor

graph paper

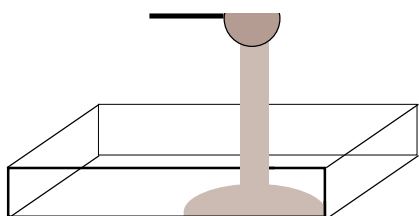

Procedure

Making an hypothesis

1. After looking at photographs of the Moon, how do you think the craters were formed?

2. What do you think are factors that affect the appearance and size of craters and ejecta?

Preparing a “lunar” test surface

1. Fill a **pan** with **surface material** to a depth of about 2.5 cm. Smooth the surface, then tap the pan to make the materials settle evenly.
2. Sprinkle a fine layer of **dry tempera paint** evenly and completely over the surface. Use a **sieve** or **sifter** for more uniform layering.

Impact Craters

3. What does this “lunar” surface look like before testing?

Cratering Process

1. Use the **balance** to measure the mass of each **impactor**. Record the mass on the “**Data Chart**” for this impactor.
2. Drop impactor #1 from a height of 30 cm onto the prepared surface.
3. **Measure** the diameter and depth of the resulting crater.
4. Note the presence of ejecta (rays). Count the rays, measure, and determine the average length of all the rays.
5. Record measurements and any other observations you have about the appearance of the crater on the Data Chart.
Make three trials and compute the average values.
6. Repeat steps 2 through 5 for impactor #1, increasing the drop heights to 60 cm, 90 cm, and 2 meters. Complete the Data Chart for this impactor. Note that the higher the drop height, the faster the impactor hits the surface.
7. Now repeat steps 1 through 6 for two more impactors. Use a separate Data Chart for each impactor.
8. Graph your results.
Graph #1: Average crater diameter vs. impactor height or velocity.
Graph #2: Average ejecta (ray) length vs. impactor height or velocity.
Note: on the graphs, use different symbols (e.g., dot, triangle, plus, etc.) for different impactors.

Impact Craters

Results

1. Is your hypothesis about what affects the appearance and size of craters supported by test data? Explain why or why not.

2. What do the data reveal about the relationship between crater size and velocity of impactor?

3. What do the data reveal about the relationship between ejecta (ray) length and velocity of impactor?

4. If the impactor were dropped from 6 meters, would the crater be larger or smaller? How much larger or smaller?
(Note: the velocity of the impactor would be 1,084 cm/s.)
Explain your answer.

5. Based on the experimental data, describe the appearance of an impact crater.

Impact Craters

6. The size of a crater made during an impact depends not only on the mass and velocity of the impactor, but also on the amount of kinetic energy possessed by the impacting object. Kinetic energy, energy in motion, is described as:

$$KE = 1/2(mv^2)$$

where, m = mass and v = velocity.

During impact, the kinetic energy of an asteroid is transferred to the target surface, breaking up rock and moving the particles around.

7. How does the kinetic energy of an impacting object relate to crater diameter?

8. Looking at the results in your Data Tables, which is the most important factor controlling the kinetic energy of a projectile, its diameter, its mass, or its velocity?

9. Does this make sense? How do your results compare to the kinetic energy equation?

10. Try plotting crater diameter vs. kinetic energy as Graph #3. The product of mass (in gm) and velocity (in cm/s) squared is a new unit called “erg.”



Clay Lava Flows

Purpose

To understand some of the geological processes and the structures that form as lava flows across planetary landscapes by using mud as an analog for lava.

Background [also see “Teacher’s Guide” Pages 3, 4, 12, 13]

In this activity students will use mud to simulate surface **lava** flows. The experiment demonstrates many of the key features of **a’a** flows, though not of whole **pahoehoe** flow fields, which are fed by lava tubes.

Real a’a lava flows are complicated. They are characterized by a prominent lava **channel** confined between levees. Shear zones, places where one portion of the flow is moving faster than an adjacent portion, usually occur. Small flows of pahoehoe lava also become channelized, but on a much smaller scale than a’a flows.

As mud is poured onto an inclined surface, the first and foremost thing to do is to observe the formation of distinct features in the flow. **Levees** form on the outer part of the flow. These are not quite the same as levees on lava flows because the latter build up levees by overflowing the banks, but nevertheless, mud flows do form levees. Inside the levees the mud moves downhill. **Ridges** might develop in the flowing portions, analogous to large ridges in lava flows. The thickness of the flow varies with slope, time, position in the flow, and amount of mud poured. These variables can be tested by measuring width and thickness as functions of time, as described in the procedure.

Preparation

Review and prepare materials listed on the student sheet.

Mix clay and water in a bucket: 5 pounds of wet clay with 4 cups of water. To mix easily, break clay into half-inch pieces and allow to dry. The mixing process should be started at least 2 days before you intend to use the clay. Cover the bucket to keep the clay mixture from hardening.

The final clay-water mixture should be fairly uniform, with only a few lumps. Smooth the mixture with a wire whisk to the consistency of thick cream. If the mixture is too runny, then it will pour like water. If it is too thick, then it will mound up (though that is interesting and somewhat resembles some very viscous lava flows).

Plexiglas is an excellent surface to use for the experiment, though any nonporous surface will do fine, such as a wooden drawing board covered with plastic wrap. If the surface is too porous, then the mud loses moisture to it, changing flow characteristics.

Clay Lava Flows

Draw a grid with 10 cm spacing onto the Plexiglas using a permanent marker pen. Or draw a grid onto paper taped to the wooden board, then cover with plastic wrap.

In Class

Using a protractor and plumb line, the Plexiglas is propped up to an angle of 15° for the procedure, then to an angle of 25° for a repeat of the procedure.

Students should pour the clay slowly and at a constant rate down the inclined Plexiglas. The bucket should be held about 10 cm from the high end of the Plexiglas.

At each 10 cm mark, the students will:

1. record the time the flow front passes the mark,
2. measure the length of the flow,
3. measure the width of the flow,
4. measure the center depth of the flow.

“Data Tables” are provided for recording these values. Space is provided for sketches of the flow outline.

When the clay is flowing down the Plexiglas, look for areas near the edges where the flow rate is low or zero; these are the levees of the channel. The part in the middle that is moving faster is called the channel interior.

Wrap-up

How do the two flows compare?

Is the ratio of channel width to flow width the same?

Presumably the clay volumes were the same for both slopes, but the flow areas could be determined and multiplied by the average depths as an exercise just to check.

Extensions

1. Use a ruler with a grid to slice into the flow at each 10 cm mark to get cross sections.
2. Can you see the levee margins in the cross sections?
3. How do the cross sections change down the length of the flow?
4. Videotape the activity.
5. Use this clay in the “Impact Craters” activity on Page 61.



Clay Lava Flows

Purpose

To understand some of the geological processes and the structures that form as lava flows across planetary landscapes by using mud as an analog for lava.

Key Words

lava flows
channels and levees
pressure ridges

Materials

clay mixture
bucket, preferably with pouring spout
wire whisk
large spatula
Plexiglas or other nonporous surface (~1/2 by 1 meter, and preferably with a grid)
protractor with plumb line
stopwatch
"DataTables"
tape measure or ruler

Procedure

1. Stir your mixture of **clay** and **water** in the **bucket**. A few lumps are acceptable.
2. Prop up one end of the **Plexiglas** at an angle of about 15° (use the **protractor** and **plumb line** to determine the angle). A board under the Plexiglas helps prevent sagging.
3. Hold the bucket of clay mixture about 10 cm downslope from the high end of the Plexiglas. Keep the bucket about 10 cm above the Plexiglas surface. Pour the clay slowly. It is important to keep the pour rate as constant as possible. Start the **stopwatch** when the flow front passes the zero line.
4. Watch the flow as it goes downhill and spreads out, and record the time it reaches each 10 cm mark. How far behind the flow front does the distinct channel become apparent?

5. Record the time when you stopped pouring (the flow will continue to move). Fill in the "**Data Tables**."

6. Note the channel and levees as well as shear zones within the levees. Does the channel extend the entire length of the flow?
-
-

Clay Lava Flows

Data Tables

Angle	Time at 0	10	20	30	40	50	60	70	80	90	Time stopped pouring
15°											
25°											

Angle	Width at 0	10	20	30	40	50	60	70	80	90	Total length
15°											
25°											

Angle	Center-line depth at 0	10	20	30	40	50	60	70	80	90
15°										
25°										

Angle	Channel width at 0	10	20	30	40	50	60	70	80	90
15°										
25°										

Clay Lava Flows

**Sketch of
flow at 15°**



**Sketch of
flow at 25°**

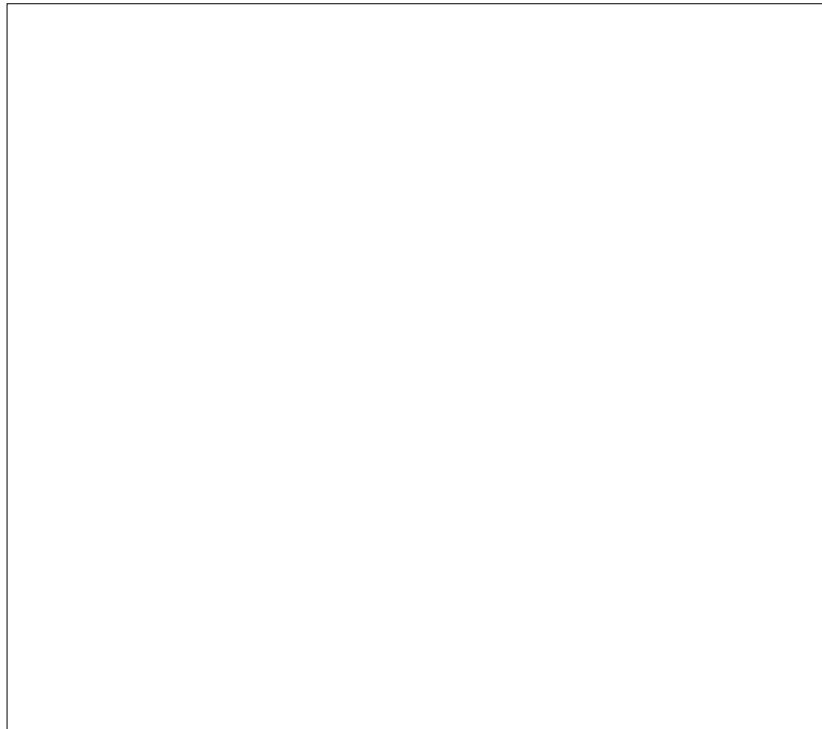

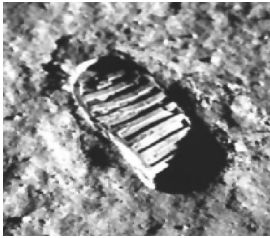

Lava Layering

Purpose

To learn about the stratigraphy of lava flows produced by multiple eruptions.

Background [also see “Teacher's Guide” Pages 3, 4, 12, 13]

Dark, flat **maria** (layers of **basaltic lava** flows) cover about 16 percent of the Moon’s total surface. They are easily seen on a full Moon with the naked eye on clear nights from most backyards. The maria, quite similar to Earth’s basalts, generally flowed long distances ultimately flooding low-lying areas such as **impact** basins. Yet, the **eruption sources** for most of the lunar lava flows are difficult to identify. The difficulty in finding source areas results from burial by younger flows and/or erosion from meteoritic bombardment.

Generally, the overall slope of the surface, local topographic relief (small cliffs and depressions), and eruption direction influence the path of lava flows. Detailed maps of the **geology** of the Moon from photographs reveal areas of complicated lava layering. The study of rock layering is called **stratigraphy**.

On the Moon, older flows become covered by younger flows and/or become more pocked with impact craters.

On Earth, older lava flows tend to be more weathered (broken) and may have more vegetation than younger flows. Field geologists use differences in roughness, color, and chemistry to further differentiate between lava flows. They also follow the flow margins, **channels**, and **levees** to try to trace lava flows back to the source area.

The focus of this activity is on the patterns of lava flows produced by multiple eruptions. We use a short cup to hold the baking soda because we are looking at the flows and not at constructing a volcano model. Volcanoes, like those so familiar to us on Earth and Mars, are not present on the Moon. Three well-known areas on the Moon interpreted as important volcanic complexes are: Aristarchus plateau, and the Marius Hills and Rumker Hills (both located in Oceanus Procellarum). These areas are characterized by sinuous rilles (interpreted as former lava channels and/or collapsed lava tubes) and numerous domes.

Lava Layering

Preparation

Baking soda-vinegar solutions and playdough are used to model the basaltic lavas. Different colors identify different eruption events; this activity calls for 4 colors. Students will be asked to observe where the flows traveled and to interpret the stratigraphy. Cover the work area and be prepared for spills.

Play Dough (stove-top recipe)

-best texture and lasts for months when refrigerated in an air tight container.

2 cups flour	1/3 cup oil, scant
1 cup salt	2 cups cold water
4 teaspoons cream of tarter	food colorings (20 drops more or less)

Make this large batch one color or divide ingredients in half to make 2 colors. You will need 4 colors total. Combine ingredients and cook mixture in a large sauce pan, stirring constantly, until the dough forms a ball. Turn dough out onto a floured surface to cool. Then kneed until smooth and elastic. Cool completely; refrigerate in air tight containers.

Play Dough (no-cooking recipe)

2 cups flour	2 Tablespoons oil
1 cup salt	1 cup cold water
6 teaspoons alum or cream of tartar	food colorings (as above)

Make this large batch one color or divide ingredients in half to make 2 colors. You will need 4 colors total. Mix ingredients and kneed until smooth and elastic. Store in air tight containers.

In Class

This activity can be done individually or in cooperative teams.

Making a vertical cut through the flows reveals, quite dramatically, the stratigraphy of the section.

Wrap-up

Have students compare their layered lava patterns with their classmates' patterns. Did they recognize individual flows by color and outline? Point out how the oldest flow is on the bottom of the stack and the youngest flow is on top.

Extensions

Groups can trade landscapes before answering the questions. Clear, plastic drinking straws can be pushed down into the landscapes to extract "drill" samples of the layers.



Lava Layering

Purpose

To learn about the stratigraphy of lava flows produced by multiple eruptions.

Key Words

eruption

source

stratigraphy

Materials

paper cups, 4 oz. size,
some cut down to a
height of 2.5 cm

cafeteria tray or cookie
sheet, 1 for each eruption
source

tape

tablespoon

baking soda

measuring cup

vinegar

food coloring, 4 colors;
for example, red, yellow,
blue, green

playdough or clay in the
same 4 colors as the
food coloring

plastic knife, string, or
dental floss: to slice
through the layers of
playdough

Procedure

1. Take one **paper cup** that has been cut to a height of 2.5 cm and secure it onto the **tray**. (You may use a small loop of **tape** on the outside bottom of the cup.) This short cup is your eruption source and the tray is the original land surface.
2. Place one **Tablespoon of baking soda** in this cup.
3. Fill 4 tall paper cups each with **1/8 cup of vinegar**.
4. To each paper cup of vinegar add 3 drops of **food coloring**; make each cup a different color. Set them aside.
5. Set aside small balls of **playdough**, one of each color.
6. You are now ready to create an eruption. Pour red-colored vinegar into your source cup and watch the eruption of “lava.”
7. As best you can, use red playdough to cover the areas where red “lava” flowed.
8. Repeat steps 6 and 7 for each color of vinegar and playdough. You may add fresh baking soda to the source cup or spoon out excess vinegar from the source cup as needed.

Lava Layering

Results

1. After your four eruptions, can you still see the original land surface (tray)? Where?

2. Describe what you see and include observations of flows covering or overlapping other flows. Use the left page margin to make a sketch.

3. Where is the oldest flow?

4. Where is the youngest flow?

5. Did the flows always follow the same path? (be specific)

6. What do you think influences the path direction of lava flows?

7. If you had not watched the eruptions, how would you know that there are many different layers of lava? Give at least 2 reasons:

Lava Layering

8. Which of the reasons listed in answer 7 could be used to identify real lava layers on Earth?

9. What are other ways to distinguish between older and younger layered lava flows on Earth?

10. Which of the reasons listed in answer 9 could be used to identify lava layers on the Moon?

11. What are other ways to distinguish between older and younger layered lava flows on the Moon?

12. Make a vertical cut through an area of overlapping playdough “lava” layers. Draw what you see in the vertical section. Color your sketch and add these labels:
oldest flow, youngest flow.

**Vertical
section
through
the flows**





Lunar Landing Sites

Purpose

To design a spacecraft for travel to and from the Moon and choose an interesting lunar landing site.

Background [also see “Teacher's Guide” Pages 2-5]

The previous Unit 2 activities introduce the Moon's rocks, surface features, and the geologic processes that formed them. With this background, students are given the challenge to plan a mission to the Moon. In this activity, teams of students design a spacecraft, choose a suitable lunar landing site, and present their ideas before the entire class. Final presentations should include speeches and visual aides such as maps, diagrams, and 3-dimensional models.

Preparation

Review and prepare materials listed on the student sheet. Schedule library time as needed.

In Class

Lead a discussion on what the students need to know about the Moon in general and about potential landing sites *before* landing. A review of the Apollo sites may help initiate a discussion.

After presenting the scenario and tasks to the class, form cooperative teams of 3-4 students. Each student will have assigned duties, as described on the reproducible “Team Duty Sheet.”

For the presentations, either 3-D models or poster-size diagrams can be made, depending on resources and time. Any one or all team members may participate in the presentations.

Scenario: NASA has given you the assignment to develop a spacecraft that can fly people safely to the Moon, land, and return to Earth. You must select a safe yet interesting lunar landing site for the spacecraft.

Size, mass, propulsion, number of crew, life support systems, and methods of takeoff and landing should be considered for the spacecraft.

Geology, terrain, safety, and length of stay should be considered for the lunar landing site.

Lunar Landing Sites

Wrap-up

1. How do the sites chosen by the class compare in location and geologic diversity with the Apollo sites?
2. What made some spacecraft designs and landing sites, in this activity, more risky than others?
3. Are these lunar landing sites good for short-term visits only, or could the sites be appropriate for lunar base development?
See the “Lunar Land Use” activity on Page 101.

Extensions

Spacecraft design could be conducted as a spin-off of the "egg drop" contest. Each spacecraft is constructed to hold and protect one raw egg. The egg must remain unbroken after landing from a high drop (perhaps a second-story balcony).

Some students may enjoy learning more details of Apollo site selections. A detailed discussion of how the sites were chosen is given in *To A Rocky Moon* by Don E. Wilhelms, Univ. of Arizona Press, 1993.

Use these lunar landing sites in the “Lunar Roving Vehicle” activity on Page 87, stipulating that the vehicle must be able to work on the terrains.

Use these lunar sites in the “Lunar Land Use” activity on Page 101.



Lunar Landing Sites

Purpose

To design a spacecraft for travel to and from the Moon and chose an interesting lunar landing site.

Materials

Moon maps
Apollo landing sites map
“Moon ABCs Fact Sheet”
Moon slides
background literature,
such as the “Teacher’s
Guide”
“Team Duty Sheet”
art and construction
supplies

Scenario

NASA has given you the assignment to develop a spacecraft that can fly people safely to the Moon, land, and return to Earth. You must also select a safe yet interesting lunar landing site for the spacecraft.

Size, weight, propulsion, number of crew, life support systems, and methods of takeoff and landing should be considered for the spacecraft. Geology, terrain, safety, and length of stay should be considered for the lunar landing site.

Procedure

1. Read the “Team Duty Sheet” given to your team.
2. Design a spacecraft with all necessary systems that can go to the Moon, land, and return to Earth. Build a model or draw a detailed diagram of the design.
3. Study maps of the lunar surface and use your knowledge of the Moon to determine a safe yet interesting lunar landing site.
4. Make a presentation to the class:
 - (a) about your spacecraft and its special features using diagrams and/or a model,
 - (b) describing, locating, and justifying the landing site.

Names: _____

Date: _____

Lunar Landing Sites

TEAM DUTY SHEET

Your team must design a spacecraft and determine a safe yet interesting place to land on the Moon.

Everyone on your team should be assigned one or more of the following duties:

Chief Engineer : oversees the entire project, helps to design spacecraft, makes critical decisions for the team.

Scientist : designs spacecraft, oversees the construction of the model or diagrams of the spacecraft.

Lunar Geologist : studies maps of the Moon and oversees the selection of a safe yet interesting place to land the spacecraft.

Public Relations Manager : helps scientist and geologist, oversees the presentation of the spacecraft and landing site before the class.

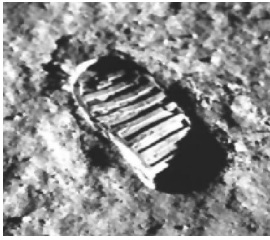

Lunar Roving Vehicle

Purpose

To construct a model of a lunar roving vehicle.

Background

The **Apollo lunar roving vehicle** was a battery-powered space buggy. The **astronauts** on Apollo 15, 16, and 17 used it to explore their landing sites and to travel greater distances than astronauts on earlier missions. The lunar rover neatly folded up inside the lunar lander during trips to the Moon. Once on the Moon's surface, it unfolded with the help of springs. The lunar rover carried two astronauts and was manually driven. It was designed to climb steep slopes, to go over **rocks**, and to move easily over the Moon's **regolith**. It was able to carry more than twice its own weight in passengers, scientific instruments, rocks, and regolith samples. The wheels on the rover were made of wire mesh (piano wire) with titanium cleats for treads. Engineers did not use solid or air-filled rubber tires because they would have been much heavier than were the wire mesh wheels. The Apollo **spacecraft** had a fixed amount of mass (payload) it could deliver to the surface, including the rover, rover batteries, scientific instruments, sample collection devices, etc. Hence, the wire-mesh wheels were important to the overall payload mass. This rover was not designed for prolonged use, and it is uncertain if future lunar explorers would use similar designs and materials for their vehicles, use new, more durable components, or turn to **robotic** rovers.

If students are interested in constructing models that actually move, then refer to Page 38 for more information on rocket and model building.

Preparation

Review and prepare materials listed on the student sheet. While commercial building sets are very popular, models can be built with more simple and recyclable materials such as cardboard boxes, tubes, cans, straws, construction paper, string, tape, pins, styrofoam trays, thread spools, balloons, rubber bands, and mouse traps (for propulsion).

In Class / Wrap Up

After construction, students should name their vehicles and write a description of the capabilities and special features.

Lunar Roving Vehicle

Extensions

Hold competitions between student vehicles with these criteria for judging:

1. Can the vehicle actually move -- by gravity; by some kind of propulsion system?
2. Can the vehicle go over different surfaces -- smooth, flat, bumpy, or inclined?
3. Is the vehicle sturdy?
4. Can the vehicle carry a heavy load? Have the students decide the weight of the load.
5. Could the vehicle withstand meteoritic bombardment?
6. Would the vehicle work on the Moon?

Discuss the pros and cons of manually driven vehicles versus remote-controlled robotic rovers on the Moon.

Diagram of the vehicle used by Apollo astronauts.

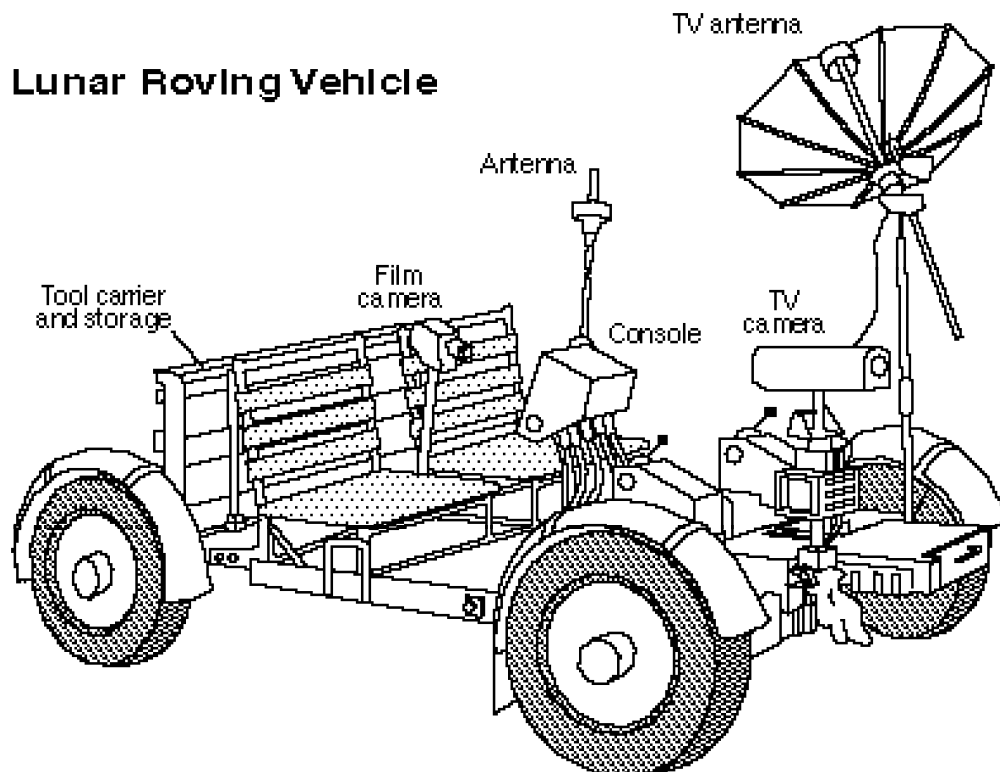



Lunar Roving Vehicle

Purpose

To construct a model of a lunar roving vehicle.

Key Words

antenna
console
tool carrier and storage
robot

Materials

diagram of Apollo lunar roving vehicle
“Moon ABCs Fact Sheet”
construction materials such as cardboard boxes, tubes, cans, straws, construction paper, string, tape, pins, styrofoam trays, thread spools, balloons, rubber bands, mouse traps, etc.
tape measures
stop watches

Procedure

1. Describe the similarities and differences between the Apollo lunar roving vehicle and a typical family vehicle.

2. What was special about the rover's wheels? Why weren't they made of rubber and filled with air?

3. Review the “**Moon ABCs Fact Sheet.**” Design a new lunar roving vehicle. Important design issues include size, weight, power supply, number of passengers, controls, scientific instruments, tools, and storage compartments. Use the space provided on the next page to draw a picture of your design. Label the parts.

4. Construct a model of the lunar rover based on your design.

5. Give a name to the vehicle.

6. Write a descriptive essay about the special features and capabilities of the vehicle and how you solved the design issues raised in Question 3.

Lunar Roving Vehicle

**Sketch of
my model**



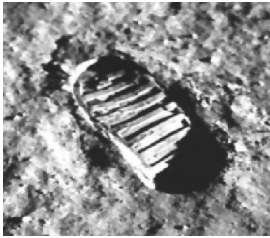

Moon Anomalies

Purpose

To investigate and try to explain various lunar anomalies.

Background [also see “Teacher’s Guide” Pages 4, 10]

In this activity teams of students present hypotheses that attempt to resolve four anomalies of the Moon. They will be expected to prepare written and oral presentations for the entire class. Using a forum format, students will debate the merits of each hypothesis, with no right or wrong answers.

The four anomalies are:

“Quakes or No Quakes, that is the Question”

“Where Have All the Volcanoes Gone?”

“Maria, Maria, Where For Art Thou?”

“Magnetic Field Forever?”

Some of these anomalies are more complicated than others. The class need not discuss all the anomalies; the most straightforward are Quakes and Missing Volcanoes.

Preparation

Review and prepare materials listed on the student sheets.

Schedule library time, if needed.

Some possible solutions to the anomalies

Quakes or No Quakes, that is the Question

The number and strength (magnitude) of **moonquakes** is much less than the number and magnitude of **earthquakes**. The probable cause of this difference is the Moon's smaller size and cooler interior. Earth is hot and active, manifested most dramatically in **plate tectonics**. Tectonic plate motions in Earth are driven by convection in the **mantle**—the solid mantle actually moves at rates of a few centimeters a year. The Moon’s mantle, too cool to move easily, has no convection and no active tectonic plate motions. Fewer movements inside the Moon mean fewer quakes. The few moonquakes that do occur are driven primarily by gravitational tugs by Earth and Sun (tides in the solid Moon).

Moon Anomalies

Where Have All the Volcanoes Gone?

The Moon has lots of **lava** flows, but no (or at least few) **volcanoes**. The clue to solving this dilemma lies in understanding why volcanoes form on Earth, Mars, and Venus. In fact, those bodies also have large expanses of lava flows that are not associated with volcanoes. For example, vast deposits of lavas occur in Oregon, Washington, and Idaho. These are called the Columbia River Basalts. They **erupted** from long cracks called **fissures** and flowed across the surface. The path the magma took was far different from that in other places. The magma never concentrated to narrow conduits that were fed periodically over a long time to form a high mountain over the site.

The transport of magma for the Columbia River basalts was controlled by the stress environment of the region. Long fissures developed which provided the magma with pathways to the surface. On the Moon, plenty of fractures occur around the rings of the multi-ringed basins. These fractures undoubtedly extend far into the Moon, and may have provided easy access to the surface for magma, and at the same time did not allow the magma paths to concentrate in one small area. Result: no large volcanoes formed. The idea that some did form but were destroyed by impacts is always a possibility on the Moon, but lots of volcano-sized mountains on basin rings survived, so one would expect volcanoes to do so, too.

Maria, Maria, Where For Art Thou?

Almost all of the lunar maria decorate the Earth-facing side of the Moon. Only a few add contrast to the **farside**. See the first two photographs in the “Teacher’s Guide” on Page 1. The most likely cause of this asymmetry is the variation in thickness of the Moon’s **crust**. The crust is lower in density than the mare-basalt magmas that must pass through it to erupt onto the surface. This, in turn, requires that the magmas have a sufficient driving pressure to migrate through the crust. Scientists think that magmas on the Moon tend to stall and collect at the base of the crust. They stay there until the pressure is enough to begin to form fissures for the magmas to travel through. On the nearside, the crust is about 70 kilometers thick. Many of the mare-basalt magmas were able to reach the surface once the pressure was large enough to form cracks. However, on the farside, the crust is twice as thick, so very few magmas could reach the surface. Most stalled on their way through it.

Magnetic Field Forever?

The lunar **magnetic field** is one of the least understood properties about the Moon. It is about 10,000 times weaker than Earth’s magnetic field. The Moon had a weak field in the past, but none is being generated at the present time.

Moon Anomalies

The most likely reason for the decline in field strength is that the Moon's tiny metallic **core** (no larger than 400 kilometers in radius) did generate a field the way Earth's core does, but the field-generating engine kept losing power. Earth's field is generated by convective motions inside the liquid portion of the core: hotter iron rises, cooler iron sinks, and the differential motions create a magnetic field. On the Moon, the whole body cooled much faster than Earth (because the Moon is smaller), so the core also cooled, and probably solidified. Motions fast enough to generate a magnetic field do not occur today inside the Moon's core.

In Class

Divide the class into cooperative teams of 4-5 students. Encourage each team to generate a team name and logo. Give each team a "Task Sheet" describing their duties. Each team then develops a hypothesis that reconciles the dilemma given them. They must work together to produce a written report describing their anomaly, hypothesis, and supporting evidence. You may want to copy and distribute all the final reports so each team has a complete set.

When the teams make their oral presentations to the class they must use visual aid materials, such as maps, posters, charts, slides, laserdiscs, etc. After each presentation, other teams may challenge the presenters with questions or arguments.

Wrap-up

After all teams have presented, lead a discussion to summarize what has been learned.

Extension

You may wish to discuss another mysterious aspect of the Moon's magnetic field: the presence of several small areas (30-60 kilometers across) that have exceptionally large surface magnetism, about 10 times the normal Moon magnetic field. These are associated with bright swirly deposits. Possible origins include impact of a comet that is highly magnetized or magnetization of a comet during impact. In either case, the magnetism is transferred to the ejecta deposits at the site of impact. Another suggestion is that the field results from giant, basin-forming impacts. It turns out that most, but not all, magnetic swirl deposits are on the exact opposite side of the Moon from a large basin (i.e., antipodal to the site of impact). The idea is that seismic waves generated by the large impact interact vigorously when they meet half way around the Moon. Somehow these interactions reinforce existing magnetic fields to create the anomaly. The whitish swirls, by the way, may form because the solar wind (mostly hydrogen nuclei) is deflected by the strong magnetic field. Thus, no hydrogen gets implanted into the regolith, and subsequent micrometeorite bombardment does not cause formation of dark agglutinates. Instead of being dark glass, the agglutinates are colorless or nearly so.

Names: _____

Date: _____

Moon Anomalies

Task Sheet

Everyone on your team should be assigned one or more of the following tasks:

Chief Strategist : oversees the entire project, works closely with all members, makes critical decisions.

Material Person : collects, cares for, and returns all materials needed for the activity.

Media Consultant : oversees development of all the visual aid materials that your team will use during the presentation, such as maps, posters, models, etc. Also coordinates the use of slides, photographs, laserdisc, computer, etc.

Administrator : keeps notes, assists media consultant, and prepares final written report.

The oral presentation may be made by any one or all team members.



Quakes or No Quakes, that is the Question

Purpose

To investigate and try to explain why the Moon has fewer moonquakes than Earth has earthquakes.

Key Words

earthquake

moonquake

Materials

maps of the Moon

background information on
the Moon

“Moon ABCs Fact Sheet”

“Task Sheet”

art supplies

Background

The Moon is safer than San Francisco—at least from earthquake damage. Each year Earth has more than 10,000 earthquakes of magnitude 4 or greater. In contrast, the Moon has less than 500, and most of these are smaller than magnitude 2.5. The largest moonquake recorded during the eight years that the Apollo seismic instrument operated on the Moon was slightly less than magnitude 5. On Earth, the largest quakes reach magnitude 8, or even 9. Finally, the total amount of energy released by moonquakes is the same as released by three 100-watt light bulbs. Earthquakes release the equivalent of 300,000,000 100-watt light bulbs.

Dilemma

Why does the Moon have fewer quakes than Earth? Is it because people live on Earth? Because the Moon is smaller? Because Earth has moving tectonic plates? Because the Moon has craters?

Task

Develop an hypothesis that explains why the Moon has fewer quakes than Earth.



Where Have All the Volcanoes Gone?

Purpose

To investigate and try to explain the absence of volcanoes on the Moon.

Key Words

volcano
lava flows
maria

Materials

maps of the Moon
background information
on the Moon
“Moon ABCs Fact Sheet”
“Task Sheet”
art supplies

Background

The dark areas of the Moon’s surface, called the lunar maria, are composed of solidified lava flows. Scientists know this from photographs that show the margins of individual lava flows and from examination of rocks returned from the maria. The lava plains cover 16% of the lunar surface and are up to about 2 kilometers thick. This is a substantial amount of lava. Scientists estimate that a total of 10 million cubic kilometers of lava erupted during a period of about a billion years to fill the mare basins. This is a lot of lava! -- enough to fill 10 billion football stadiums! Most of the maria occur inside the huge circular impact craters called multi-ringed basins. The formation of these immense craters did not cause the formation of the lava that made the maria, but the basins did provide low areas into which the liquid lava flowed.

Dilemma

Ten million cubic kilometers of lava flowed across the Moon’s surface, yet there are no obvious source volcanoes. There are no mountains that rise dramatically as they do in Hawai’i or the Cascades of the Pacific Northwest. If there are no volcanoes on the Moon, then what is the source of the lava? Were the volcanoes destroyed? Did the lava erupt in some other way? What other ways could lava erupt?

Task

Develop an hypothesis that resolves the missing volcanoes dilemma, without rejecting the idea that the maria are composed of solidified lava flows.



Maria, Maria, Where For Art Thou?

Purpose

To investigate and try to explain why the farside has fewer maria than the nearside of the Moon.

Key Words

maria

crust

lava flows

Materials

maps of the Moon

background information on the Moon

“Moon ABCs Fact Sheet”

“Task Sheet”

art supplies

Background

About 16% of the Earth-facing side of the Moon is covered with dark maria. But less than 1% of the farside is covered with maria. Scientists think that the magmas were formed inside the Moon by melting of the Moon’s mantle, and that these magmas then moved to the surface. They probably moved in long cracks. Good evidence suggests that the crust on the farside is about two times thicker than on the nearside.

Dilemma

Assuming magma was generated throughout the Moon’s mantle, why are almost all the maria on the nearside of the Moon? Did they get covered up by other rocks on the farside? Did Earth’s gravity help them get out onto the nearside? Was it too hard to travel through the thick, farside crust?

Task

Develop an hypothesis that resolves the maria-are-more-abundant-on-the-nearside dilemma.



Magnetic Field Forever?

Purpose

To investigate and try to explain why the Moon has a weaker magnetic field than does Earth.

Key Words

magnetic field
core

Materials

background information
on the Moon
“Moon ABCs Fact Sheet”
“Task Sheet”
art supplies

Background

The Moon has a much weaker magnetic field than does Earth. However, the field was stronger in the past, as shown by study of the magnetic properties of lunar rocks. Earth's magnetic field is formed by motions inside its iron core. The Moon also has a core, but it is much smaller than Earth's core. The Moon's core is no larger than 400 kilometers in radius, and may be as small as 100 kilometers. In contrast, Earth's core is 2900 kilometers in radius.

Dilemma

The Moon had a stronger magnetic field in the past (billions of years ago), but it is weak now, much weaker than Earth's magnetic field. Why is it so much weaker than Earth's? Why was it stronger in the past?

Task

Develop an hypothesis that explains why the Moon has a weaker magnetic field than does Earth, and why the Moon's field was stronger in the past.