

Exploring Meteorite Mysteries

Lesson 13 — Solving a Mystery

“How
did they
form?”

Objectives

Students will:

- conduct an investigation.
- observe and record the physical characteristics of an unknown rock (meteorite).
- determine the mass of the unknown rock using math skills to track sample chips.
- determine the density of a rock.
- describe and classify a meteorite.
- apply observations and knowledge to the process of a scientific investigation.
- present evidence to verify classification decisions.
- explore concepts of spatial relationships.

Lesson Structure (All parts A-D are necessary for completion.)

Four photographs provide the evidence for the students' investigations. The goal is to gather enough information to identify the unknown rock in the photograph. At each step the students will check whether there is enough data to identify the unknown, or at least eliminate some of the possibilities.

Part A. Looking for Clues

- Start investigation of unknown by observing the rock in Lithograph I.
- Emphasis is on describing color, texture, and shape.
- Use Lithograph II to view from a different perspective.

Optional

- Construct paper cube and use a die to develop understanding of spatial relationships.
- Manipulate the orientation cube used with meteorite samples to understand why it is important.

Part B. Vital Statistics

- Measure the dimensions of the unknown (Lithograph I and II).
- Determine the density of the rock.

About This Lesson

This is a culminating lesson in four parts. It is designed to follow meteorite identification activities. A minimum sequence is Lessons 1, 8, 9, 10, 11, and 13. It would also be useful after geologic sample identification activities. The goal for the class is to gather enough information to identify the unknown rock. This will be accomplished by using photographs to observe, describe, measure, illustrate, and classify the “unknown” (Noblesville meteorite). Scientific identification processes will be simulated. As the class progresses through each step of the activity they will be asked “What would be your next step to classify this rock?”. The teacher will lead the students to recognize the need for additional, usually more detailed, information. Stress that even though they may guess or have a “hunch” what the unknown is (a meteorite), **they must present evidence to verify their decisions.** See “Hints” throughout the procedure.

Part C. Narrowing the Suspect List

— Observe the interior of the rock in detail (Lithograph III).

Part D. Nabbing the Culprit

— Use a microscope photo of a thin section of the rock to complete the identification (Lithograph IV).

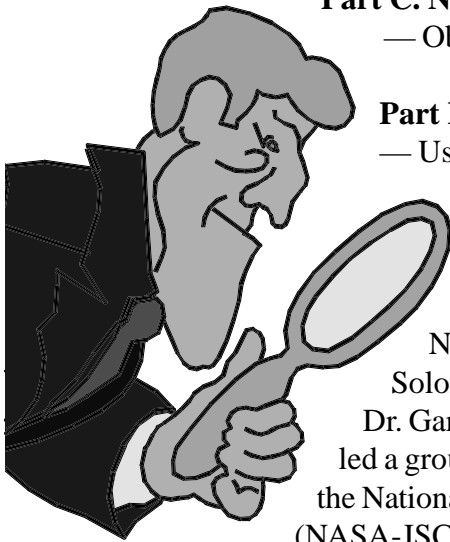

Background (See also Lesson 1)

After Brodie Spaulding and Brian Kenzie observed the fall of the Noblesville meteorite, they sent the specimen to astronomer Dr. Solomon Gartenhaus at Purdue University for classification and study. Dr. Gartenhaus contacted Purdue meteoriticist Dr. Michael Lipschutz who led a group of scientists to study the meteorite. He arranged for curation at the National Aeronautics and Space Administration's Johnson Space Center (NASA-JSC). The meteorite was sent to NASA for initial description and classification by the curators at the lab. The curators photographed, weighed, measured, and described the meteorite, then took 20 grams of chips for further scientific study. One chip was used to prepare thin sections for mineral analysis and microscopic textural observations. They found that Noblesville is a meteorite breccia consisting of numerous large white clasts in a dark gray matrix.

Abundant metal and a few small chondrules can be seen in the specimen, showing that it is a metal-rich chondrite. Mineral analyses confirmed the high-iron nature of both clasts and matrix and showed that the clasts are highly metamorphosed, while the matrix is only slightly metamorphosed. This type of chondrite breccia is rare. It is a regolith breccia similar to some lunar breccias. The curators also sent chips of the meteorite to several geochemists for elemental and isotopic analyses. These scientists found that Noblesville is rich in gases deposited by the solar wind.

Vocabulary

astronomer, attrition, breccia, chondrite, chondrule, classification, clast, curation, curator, density, fusion crust, geochemist, isotope, matrix, metal, metamorphic, meteoriticist, regmaglypt

Advanced Preparation

1. Be familiar with background information and comfortable with vocabulary (see glossary).
2. Assemble all materials and be very familiar with the order in which they will be used.
3. If only one original set of photographs is available, good photo copies will work. Use copies for the groups and display originals for consultations.

Lesson 13 — Solving a Mystery

Part A: Looking for Clues

Objective

Students will:

- observe and record information from close examination of two photographs of the unknown rock.

Procedure - Step 1

Suggested introduction to be used by teacher:

Have you ever been confronted with a real mystery?

- *Someone has written an anonymous love note to you, and you can't figure out who it is!*
- *Something has disappeared and you KNOW it was there a minute before.*
- *You've found something weird and you can't figure out what it is or where it came from.*

Some professionals spend their entire careers solving mysteries for people. THIS time, YOU will be the investigators.

1. Divide class into groups of 3-5 students.
2. Students examine Lithograph I as a group and using the Team Data Sheet write individual descriptions of the rock. Include shape, color, texture, and hypothesize as to its identity. Allow students to check original color photo if they are using photo copies.
3. Students may share descriptions and hypotheses.
4. Solicit ideas for further investigation and lead students to recognize the need for more information — a picture of the rock from a different perspective.

Hint: Students may ask for the actual rock. Point out that private investigators often search for missing persons and have only a photograph for their first clue.

Procedure - Step 2

1. Examine Lithograph II. Students record similarities and differences of the two photographs (Lithos I and II) on the Team Data Sheet. Focus on big rock, not small pieces.

About Part A

Students will start their investigation by observing the rock in photographs.

Materials for Parts A-D Per Group of Students

Note: Materials should be distributed as needed for each step of the investigation.

- Lithograph Set (*Lithographs I-IV show 4 photographs of Noblesville meteorite*)
- Lithograph copies if needed
- Suspect List, pg. 13.15, (*used in Parts C and D*)
- Team Data Sheet, pgs. 13.13-13.14, (*per student*)
- Meteorite ABC's Fact Sheet (*pgs 29-30*) (*used in Part D*)
- NASA JSC Notes - Extended Comments (*pg. 13.11*)
- individual writing materials
- paper clips
- transparency or similar plastic sheet
- transparency marker
- metric ruler
- one overhead projector for class
- single die - optional
- patterns for orientation cubes for each student - optional (*pg. 13.12*)
- scissors
- glue

Hint: Two photographs of the same person often look like different people. A different perspective can make a big difference.

2. Allow students to discuss comparisons, and reveal all evidence they have observed.

Hint: Exterior “coat” which could be fusion crust should be identified by this point; therefore, this rock “may be a meteorite.” Since they have presumably been studying meteorites this is a logical step since hypotheses come from evidence coupled with prior knowledge. But they must present evidence!

Looking for Extra Clues

Optional Extension

(use after Part A)

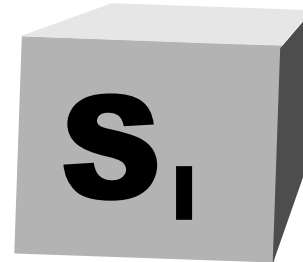

Objective

Students will:

- explore concepts of spatial relationships.

Procedure

Suggested introduction:

Just as an investigator might start off with a photograph of a missing person, we have two photographs of an unidentified rock. Is there anything else in either photograph that might provide additional clues about this rock? (Lead class to notice orientation cube if necessary.) What do you think the little block is? (Point out letters. Solicit comments.)

Sometimes investigators make simulations of items they can see in photographs. I have some patterns to make cubes. If we experiment, maybe we can figure out why cubes are in both of the pictures?

1. Distribute individual cube pattern sheets and scissors.
2. Students label sides of cube shown in pictures. This may be done after construction if desired.
3. Teacher leads class in supplying “missing” letters and students finish labeling cubes.

Hint: Looking at the two cubes, I see the letter ‘E’ on both of them. Assuming that both cubes are identical, how would the ‘T’ and ‘B’ relate to each other? (Opposite each other — T for Top & B for Bottom) Now that we’ve dealt with the T and the B, let’s look at the leftover letters. Where have you seen an N and an E together before? What could they stand for? (North and East) If students do not recognize the letters as directions, identify them as such. S and W are not visible in the photographs but students should put them on their cube model.

4. Students fold and glue cubes.
5. Teacher solicits possible uses for cubes.
6. Students relate cubes to picture, determining that the rock has been turned upside down in the second photograph.

Hint: When police arrive at a crime scene, it is common practice to orient objects (bodies) using strips of tape before photographing the scene. This allows for effective “further investigation.”

7. Demonstrate the use of orientation cube using die.
 - Group leader will place cube next to die on lab table with the cube’s “T” face on top and “N” face indicating north. Die should be placed with “5” and “6” faces of die oriented to “T” and “N” respectively.
 - As other members of each group record instructions, group leader will flip or rotate both the cube and die **simultaneously** as teacher calls out and models instructions. *Note: Both die and cube **must** be flipped or rotated the **exact** same number of times in the **exact** same direction(s).*
 - Teacher will point out that the relationships of the “T” and “5” as well as the “N” and “6” are still the same after the first few instructions.
 - Teacher will verify comprehension.
 - Group leader, aided by recorded data of teammates, will return both die and cube to initial placements and orientations.
 - Groups will divide into two teams each. While one team looks away, the other team will change the orientation of the die and cube simultaneously, flipping and rotating at least 3 times (one teammate must record “moves”).
 - The inactive team will attempt to return both the die and cube to their initial positions without help (if asked, the active team may give hints after a reasonable effort has been made).
 - Teacher will support teams struggling with task throughout exercise.
 - Teams will switch “jobs.”
8. Class will work with cubes, and demonstrate initial orientation of a variety of objects in the classroom.

Hint: Noting the placement of cubes in photographs, we can determine the exact placement of an object when it was found: both “which end was up” and its geographical orientation (whether it was “facing” north, south, etc.). If items must be moved, either during a crime or scientific investigation, the investigator often must duplicate the scene. Without orientation devices, this would be impossible. Geologists use this technique when they saw rocks into pieces. They must know exact placements of parts in relation to the original specimen, particularly when they are being held accountable for national treasures like the lunar samples or rare meteorites.



Lesson 13 — Solving a Mystery
Part B: Vital Statistics

About Part B

Students will take measurements and determine the density of the specimen.

Optional

1. Optional - Students may calculate the approximate density (grams per cubic centimeter).
2. Bonus Question - Ask students how an investigator could find the volume of an irregular object. Answer could be the standard liquid displacement procedure or a new computer imaging process.

Hint: If density is calculated, “iron meteorite” may be eliminated at this point (iron density = 8, stone density = 3.3 - 4.5) Actual Noblesville Density is 3.9.

Objectives

Students will:

- measure the size of the unknown rock.
- determine the mass of the unknown rock using math skills to track sample chips.
- estimate the density of a rock.

Procedure - Step 1

Suggested introduction:

Just as an investigator needs vital statistics on a missing person, measurements are the next logical step in identifying this rock. For all we know, this thing is as big as a house. Is it a pebble or a boulder? How can we find out its size?

1. Solicit suggestions as to how the rock might be measured.
2. Disclose actual dimensions of cubes in photographs. Cubes are 1 cm on a side, not the same size as cube in optional step.
3. Groups measure or estimate dimensions of unknown, based upon Lithographs I and II and record data on the Team Data Sheet.
4. **Optional:** Class may average data to estimate size or they could create a table or graph based on the data.

Procedure - Step 2

1. Students find the total mass of all the parts of the unknown.
2. Have students compare initial mass of the unknown and the total mass of broken pieces (see Team Data Sheet for data). The difference is 0.1g (not 4.1g - some may neglect to include the 4g piece removed prior to processing at NASA).
3. Class will hypothesize about reasons for the difference in mass. The difference is due to attrition, fine dust and tiny pieces lost in sample processing. However, some students might suggest a weighing mistake or a rounding error (both are possible).

Lesson 13 — Solving a Mystery

Part C: Narrowing the Suspect List

Objectives

Students will:

- describe and draw details of an unknown rock.
- apply observations and knowledge to the process of a scientific investigation.

Procedure

Suggested introduction:

If you get a present and want to know what it is, you might shake it, heft it, sniff it, etc., but you will eventually OPEN it. We've examined the rock in our photograph pretty thoroughly. Where do we go from here? (Solicit "look inside" response.)

Looking inside something is another typical investigative technique. Since we don't have the actual rock we're attempting to identify, we'll use an additional photograph of the interior of the rock. The inside was exposed when a section of it was removed.

This magnified photograph is helpful because it allows us to see INSIDE the rock. What additional clues can we obtain from this detailed view of the unknown rock? (Solicit answers.)

Investigators often use another technique when attempting to locate a suspect. They call in a police artist and, based on descriptions of witnesses, compile an artist's sketch.

Your job is easier than that. I'd like you to examine this detailed view and prepare an artist's sketch of it.

1. Students examine Lithograph III as a group. Each student will draw this detailed portion of the unknown. Labels will be added after step 3 below.
2. Distribute Suspect Lists and have students fill in their observations based on the investigations to this point.
3. Teacher will lead students to begin the narrowing process.



About Part C

Observations of the interior of the specimen are made.

Just as investigators label drawings to clarify information, I'd like you to label your drawing. Since it appears more and more that this rock may be a meteorite, try using terms from this word bank for your labels: breccia, chondrules, clast, fusion crust, matrix, metal.

4. Instruct students to label their illustrations with at least three appropriate vocabulary words. Depending on the level of experience students have with meteorites, the words may be from a word bank or from the students' previous studies.

Hint: *The texture of the unknown is a breccia texture — clasts (broken fragments) contained in a matrix. Carbonaceous chondrite will be eliminated at this point (very few black veins and little matrix). If chondrules are recognized, achondrite may also be eliminated.*

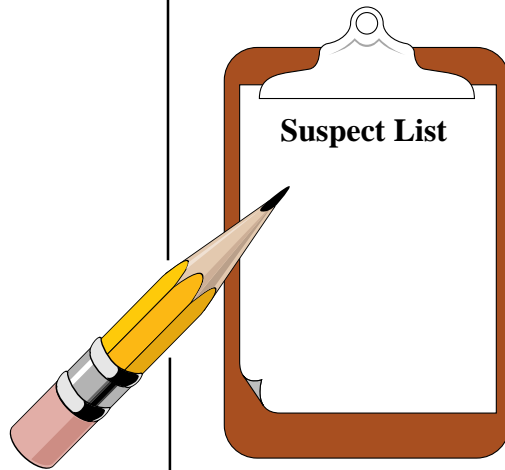

Lesson 13 — Solving a Mystery
Part D: Nabbing the Culprit

Objectives

Students will:

- observe and draw detailed microscope view of unknown.
- present evidence to verify classification decisions.

Procedure

Suggested activity introduction:

We've observed and recorded information about our rock from more than one perspective. Any ideas on a next step? I'm remembering a picture I've seen of an investigator peering at something on the floor through a magnifying glass — like Sherlock Holmes. Why would he have done that? (To make things look larger so more details may be seen.) With all the technology available to us now, how would a modern investigator accomplish that same thing? (Microscope)

Along with microscopes, modern investigators now have special cameras they can attach to microscopes for taking pictures. Geologists have even figured out a way to cut a skinny little piece of rock that is so thin that light will pass through. It's called a thin section. Lithograph IV is a thin section of our rock. This is what scientists see through a special microscope.

1. Groups will receive transparency sheet and marker. They will lay the transparency sheet over lithograph of thin section and secure with paper clips. Trace corners on transparency to make it obvious if the paper slips.
2. Possible chondrules and bits of metal, (shaded) will be traced. (Metals block light and look black under the microscope.)
3. Groups will compare transparencies by aligning and stacking them on the overhead and viewing simultaneously to detect differences in observations. Help students clarify the clast boundaries.
4. Using the Suspect List the class will attempt to eliminate “suspects” by process of elimination. If further information is needed, students may use the Meteorite ABC’s Fact Sheet on pgs. 29-30, of the Teacher’s Guide.

Hint: *Chondrules WILL be identified at this point; therefore, achondrite is eliminated. If density has not been calculated*

About Part D

Students use a microscope photo of a thin section of the rock to complete the identification.

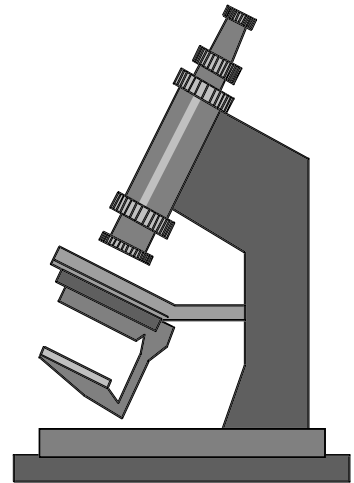

then students will need to use the photographs and descriptions in the Introductory materials to eliminate iron and stony-iron. See the Background Information on pg. 13.2 of this lesson for a detailed description of the Noblesville meteorite.

5. Class will discuss/summarize investigative process and conclusions reached.
6. Students will only be expected to identify the unknown as a chondrite or possibly as a chondrite breccia. Noblesville is a metamorphic regolith breccia made of clasts of H chondrites in a matrix.
7. Teacher will identify the rock as the Noblesville meteorite and the original investigators as the meteoriticists who identified and classified it.
8. Class will compare and contrast the descriptions of the meteorite prepared by the students with the initial descriptions prepared by NASA scientists at the Johnson Space Center. See NASA JSC Notes - Extended Comments pg. 13.11.

Lesson 13 — Solving a Mystery
NASA JSC Notes

Use only after students have completed Part D

**Initial description prepared by NASA scientists
at the Johnson Space Center**

Compare this description with students' descriptions of Noblesville.
Point out similarities in their descriptions but do not expect students' observations to be exact.

NASA JSC

Notes / Extended Comments

Sample: **Noblesville** *non -Antarctic meteorite*

Description By: Satterwhite 10/17/91

Dimensions - 9.5 x 8 x 3.5 cm

Exterior of this sample is covered with dull black fusion crust. Bottom surface of exterior is brown, top surface has several regmaglypts and some residual dirt. Small area on exterior is chipped away and reveals a medium grey matrix with some white angular clasts.

Interior is fine-grained medium grey with numerous angular white clasts. A few distinct chondrules are visible. Some very small chondrules and fragments are seen. Abundant fragmented grains with metallic luster are visible. White clasts are coarser grained. More metal sulfide and some medium-grained yellow grains (olivine?).

Weathering - A+ recent fall

Fractures - A

Weight - 483.7 g



Orientation Cube Pattern

(not same scale as photographs)

1. Cut out pattern.
2. Fold along lines to make a cube shape.
3. Glue tabs to inside of cube.

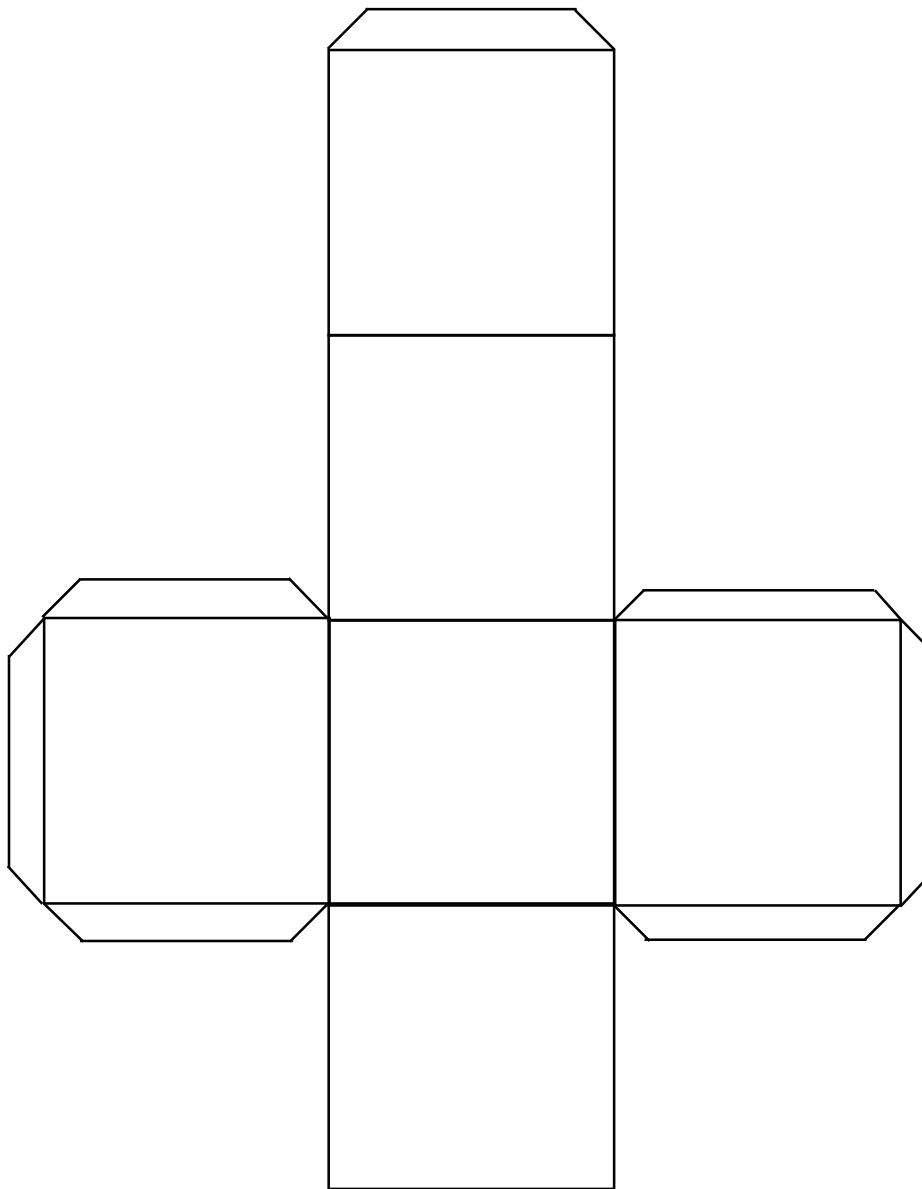

Lesson 13 — Solving a Mystery
Team Data Sheet

Name: _____

Team: _____

Part A: Looking for Clues

Step 1: Lithograph I

Describe the rock (shape, color, texture, etc.) What do you think it is?

Step 2: Lithograph II

View both photos and record the similarities and differences revealed about the rock.

Part B: Vital Statistics

Step 1:

How big is this rock?

Estimate the rock's volume in cm^3 . Why is this estimate not very exact?

Step 2: Finding the rock's mass

The mass of the rock described in the NASA Lab was 483.7g before chips were chiseled off for scientific studies. A small 4.0g piece was removed before it arrived at NASA, thus the total initial mass of the rock was 487.7g.

What was the total mass of the rock including all the pieces? (chip 0 weighed 466.4g, chip 1 weighed 12.4g, chip 2 weighed 1.6g, chip 3 weighed 3.2g)

Why was there a difference in the original weight and the total weight of the pieces?

Step 3: Optional

Estimate the rock's density in g/cm^3 , showing your math. How could this estimate be inaccurate? How should you adjust your estimate?

Part C: Narrowing the Suspect List

Sketch the inside of the mystery rock using Lithograph III. Note significant features observed.

Part D: Nabbing the Culprit

Trace the features shown in the microscope photograph onto a transparency sheet. Show detail. Use the space below to describe what you see in Lithograph IV.

Lesson 13 — Solving a Mystery
Suspect List

Name: _____

Yes or No	Reason (<i>be specific</i>)
<p>Earth Rock</p> <p>Sedimentary</p> <p>Igneous</p> <p>Metamorphic</p>	
<p>Meteorite</p> <p>Iron</p> <p>Stony - <i>Chondrite</i></p> <p> - <i>Carbonaceous</i> <i>Chondrite</i></p> <p> - <i>Achondrite</i></p> <p>Stony-Iron</p>	