

EXPLORING  
THE **EXTREME**

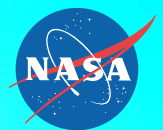

NASA Aerospace Technology



# ANGLE MEASUREMENT OF AIRCRAFT WINGS AND TAILS

## A CLASSROOM ACTIVITY FOR GRADES 5- 8

### Mathematical Topics

geometry, angle measurement

### Standards

The National Council of Teachers of Mathematics Standards recommend students in grades 5-8 be able to:

- Represent and solve problems using geometric models.
- Understand and apply geometric properties and relationships.
- Develop an appreciation for geometry as a means of describing the physical world.

Facility with a protractor is important in developing the concepts of "angle" and "angle measure." Hands-on experience with a protractor helps the students to begin to visualize geometric relationships and assists them in making realistic estimations as a means of problem solving. This activity provides students with a real-life situation using measurement. This activity also makes students familiar with basic technical drawings of aircraft, called 3-views, which are commonly used by aeronautical engineers. A 3-view represents an aircraft as seen from the top, front and side.

### Background

NASA and its predecessor, the National Advisory Committee for Aeronautics (NACA), have been on the forefront of aeronautical engineering since 1915. NASA engineers are constantly striving to achieve optimal efficiency of each new aircraft for its specific use. This has resulted in designs with tails and wings protruding at every type of angle.

In this activity, students will use a protractor to measure the angles of wings and tails of different aircraft to demonstrate the diversity of aeronautical engineering. Students will be introduced to mathematical vocabulary describing angles and their measurement: perpendicular, acute, obtuse, congruent, adjacent, complementary, supplementary, and straight angles. While estimating and measuring angles, students will learn about various NASA research aircraft being developed and tested, and how these aircraft are advancing our knowledge in terms of scientific and aerodynamic research.

### Materials

Overhead transparency of F-15 ACTIVE 3-view drawing (made from a copy of the Student Page)

Paper copies of the F-15 ACTIVE 3-view for the students (Student Page)

Protractors

Overhead marker

Copies of two aircraft 3-views selected from the right columns of the activity: HiMAT, F-8, X-15, and YF-12A. Electronic versions of the drawings are available at the NASA Dryden Flight Research Center Research Aircraft Graphics website at:

<http://www.dfrc.nasa.gov/gallery/graphics/index.html>

### The Activity

Allow the children a few moments to explore their protractors. They may examine them, trace, or draw lines with them. Following the exploration, ask the following questions: For what purpose do you think the protractor is used? How do you think the measurement is done? Explain that aeronautical engineers must determine the exact angles of the wings on their aircraft. The students are going to evaluate some of these angles by using their own protractors with 3-view drawings of NASA research aircraft. Introduce the students to the proper use of a protractor. Distribute copies of the F-15 ACTIVE 3-view to the class.

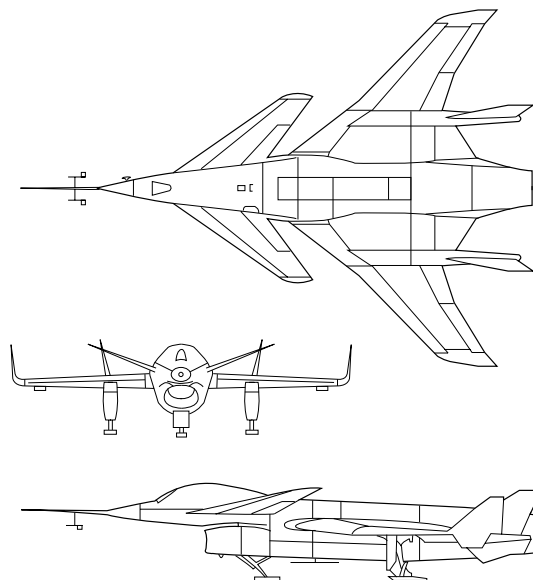

**HiMat**  
**(Highly Maneuverable Aircraft Technology)**

## Perpendicular Lines

Using the drawing of the F-15 ACTIVE on the overhead, the teacher will demonstrate how to use the protractor to measure the angles of the wings. The students should follow along using their copies of the diagram. The F-15 ACTIVE has wings and a tail that stand at nearly 90-degrees (perpendicular). Define perpendicular. *Two lines are perpendicular if they intersect at right angles. Right angles measure 90 degrees.*

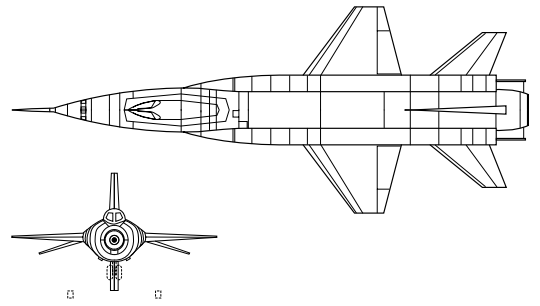

## Straight Angles

Holding the protractor on the F-15 ACTIVE drawing the students can see that the wingspan extends at 180-degrees. Discuss the term straight angle. *A straight angle is an angle that measures 180 degrees.*

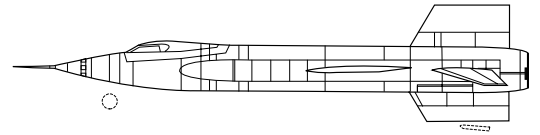

## Supplementary, Adjacent, and Congruent Angles

Next, define supplementary angles. *Supplementary angles are angles whose sum is 180 degrees.* Ask the students to look at the angles on each side of the F-15 ACTIVE tail. How do they relate to each other? Explain how these angles are adjacent to each other, and that they are also congruent. *Two angles are considered to be adjacent if they share a common side. Two angles are congruent if they have the same measure.*

## Measuring Angles

Next, each student will have the opportunity to select two other aircraft drawings (see materials) to measure. Before measuring these angles, the students should record an estimation of the angle of the wings of their aircraft. Next, they will check their estimations by actually measuring the angles with their protractors. Students should record actual measurements. Allow students to also examine the work of students who measured different aircraft.

## Obtuse Angles

Follow up with an entire class discussion on each of the different aircraft. Discussions can be generated involving the characteristics of the individual aircraft. For instance, the F-8's wings illustrate good examples of obtuse angles. *An obtuse angle is an angle that has a measure greater than 90 degrees but less than 180 degrees.*

## Acute Angles

Acute angles can be found on the HiMAT, F-18A, and on the underside of the X-15. *An acute angle is an angle that has a measure greater than 0 degrees but less than 90 degrees.* Have the students compare the results of their collective work. How close were different students' measurements of like aircraft? Who found angles on their aircraft in places other than the traditional wingspan? What was their measure?

## Extensions

There are many other aircraft line drawings available through the NASA Dryden Flight Research Center Research Aircraft Graphics website at <http://www.dfrc.nasa.gov/gallery/graphics/index.html>. Students may choose to locate two or three of these drawings for additional measurement activities and then share their newly acquired information with the class after measuring the angles in new aircraft.

X-15

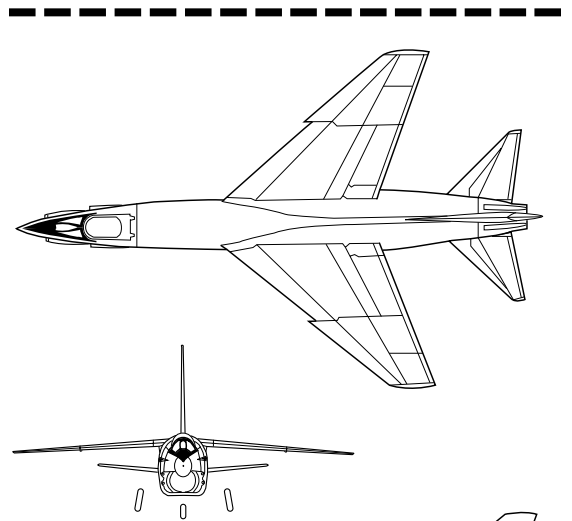

F-8

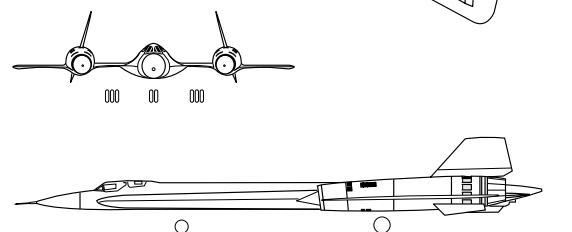
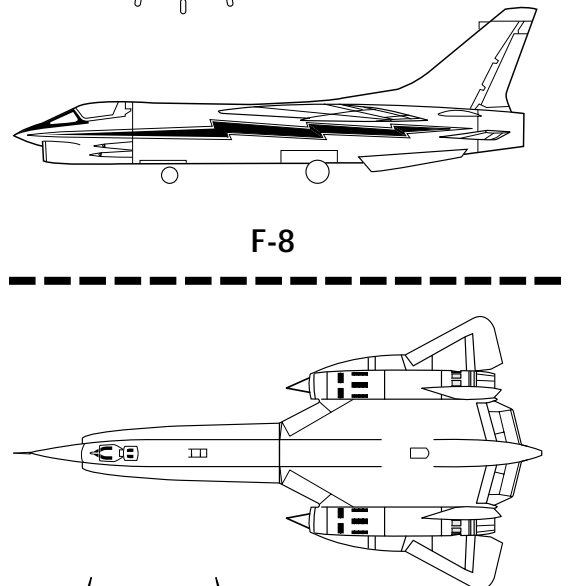

YF-12A

An on-line version of this activity can be found at the "Math Activities for K-12 Teachers" website. Developed by California Polytechnic State University and NASA Dryden Flight Research Center, this website offers dozens of activities that are based on NASA aeronautics.

### Math Activities for K-12 Teachers

<http://daniel.aero.calpoly.edu/~dfrc/Robin/>

Students may read more about NASA aircraft and view hundreds of photos at these websites:

### NASA Dryden Fact Sheets

<http://www.dfrc.nasa.gov/PAO/PAIS/index.html>

### Dryden Research Aircraft Photo Gallery

<http://www.dfrc.nasa.gov/gallery/photo/index.html>

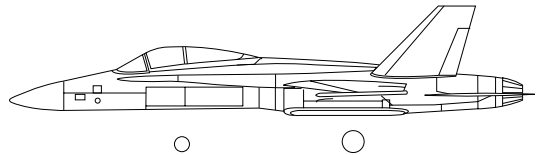
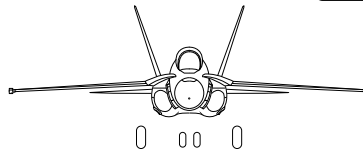
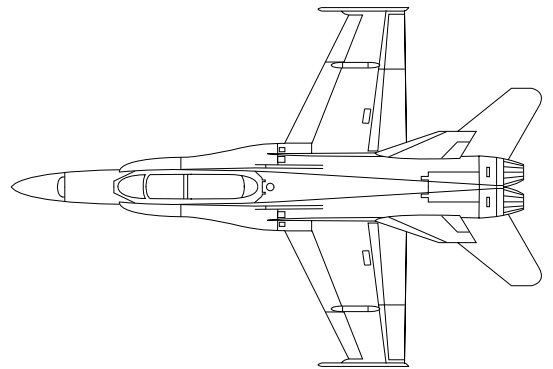

F/A-18A

## NASA Education Web Sites

NASA Education Home Page  
Information about all of the NASA Education Programs.  
<http://education.nasa.gov/>

### NASA Spacelink

NASA Spacelink is one of NASA's electronic resources specifically developed for the educational community. Spacelink is the official home to electronic versions of NASA's Education Products (including this poster and the F-15 ACTIVE Educator Guide), and includes links to other education resources.

<http://spacelink.nasa.gov>

### NASA's Learning Technologies Project (LTP)

NASA's Learning Technologies Project (LTP) includes a suite of Internet projects that teachers and students can use to explore NASA resources and learn about NASA missions. LTP offers a wide variety of educationally sound, standards-based projects that help educators explore science, math, and engineering from the classroom.

### LTP HOME PAGE:

<http://learn.ivv.nasa.gov/>

#### Poster Credits

Front: Concept by Marianne McCarthy and Ted Huetter.  
Photo illustration and design by Ted Huetter.  
Back: Classroom activity by Dr. Robin A. Ward. Layout and editing by Ted Huetter. Aircraft drawings by Dennis Calaba. Layout support by Steve Lighthill.  
This poster produced by the NASA Dryden Flight Research Center Education Office.



## NASA Aerospace Technology Enterprise

The NASA Aerospace Technology Enterprise (AT) is one of the four NASA Strategic Enterprises established to address key agency activities in distinctly different areas. The Aerospace Technology Enterprise's work in science and technology is aimed at sustaining U.S. leadership in civil aeronautics and space transportation. For over 75 years, NASA and its predecessor, the National Advisory Committee for Aeronautics, have worked closely with U.S. industry, universities, and other Federal agencies to give the U.S. a preeminent position in aeronautics. NASA has expanded this relationship to include aerospace companies, and is now working to revolutionize America's space launch capabilities.

### NASA Aerospace Technology Home Page

<http://www.aero-space.nasa.gov/>

Please take a moment to evaluate this product at [http://ehb2.gsfc.nasa.gov/edcats/educational\\_wallsheet](http://ehb2.gsfc.nasa.gov/edcats/educational_wallsheet). Your evaluation and suggestions are vital to continually improving NASA educational materials. Thank you.



EW-1999-10-003-DFRC

# Student Page

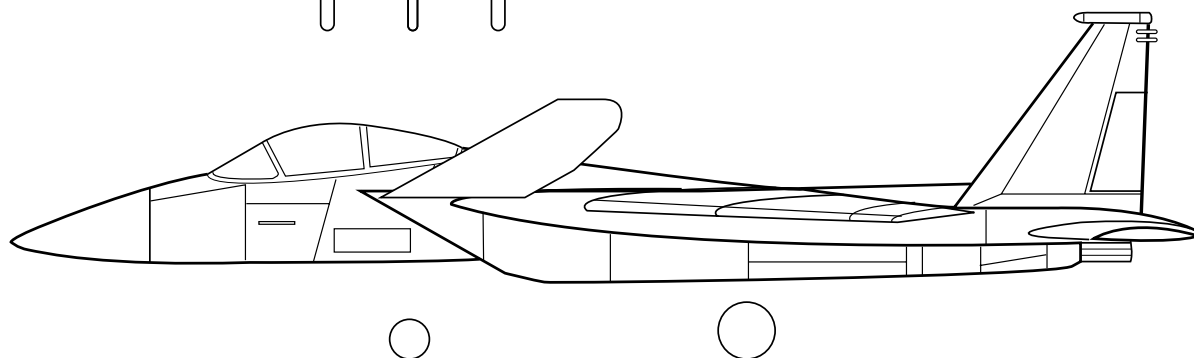
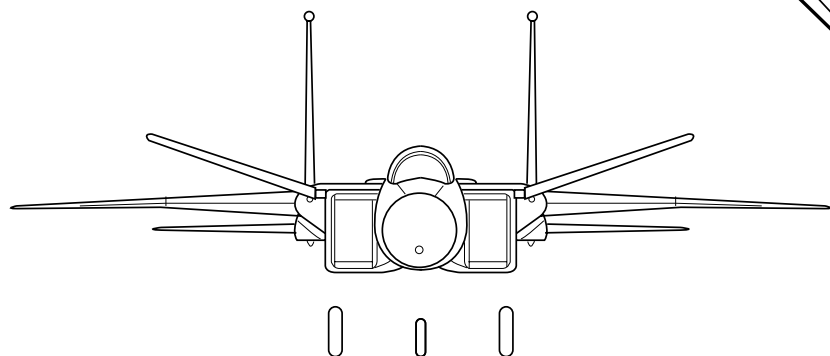
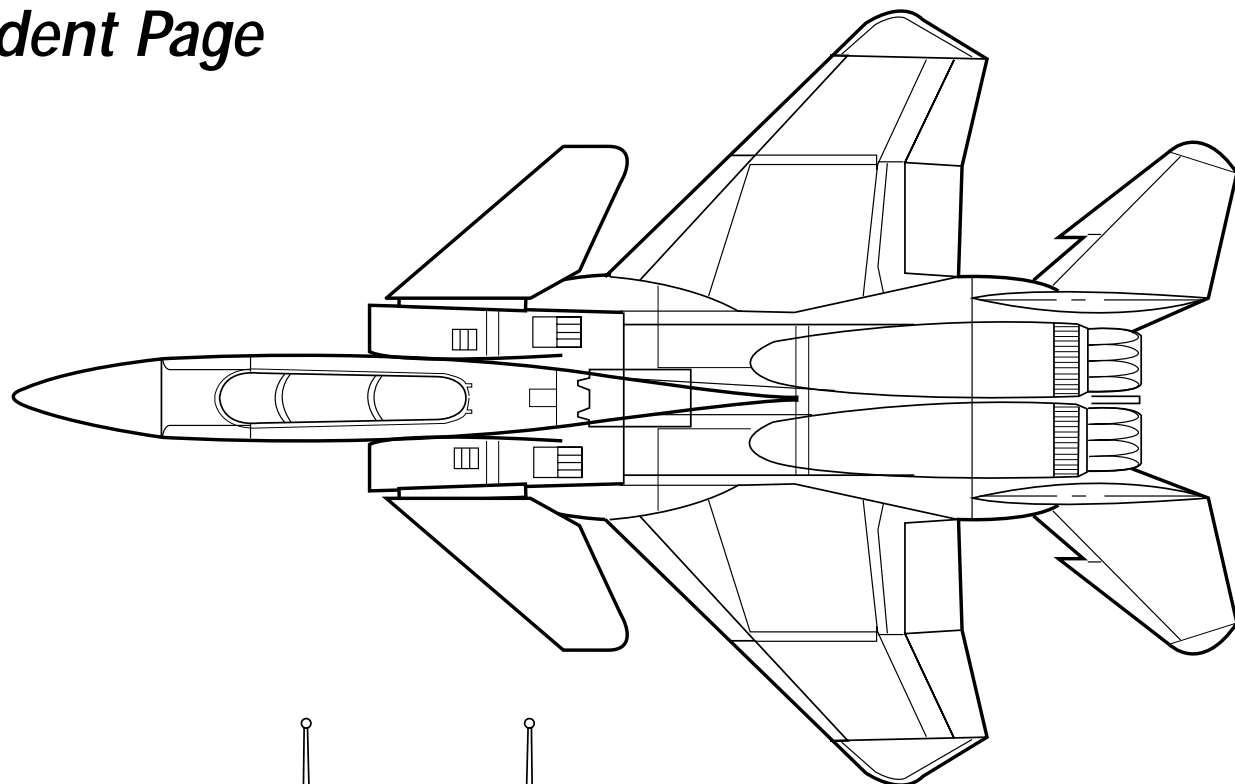

## NASA F-15 ACTIVE

This highly modified F-15 fighter was just one of the aircraft used by NASA to explore the extreme limits of aerospace technology. The aircraft was built in 1972, and modified for the U.S. Air Force's Short Takeoff and Landing Maneuvering Technology Demonstrator (STOL/MTD) flight research program which lasted from the mid-1980s until 1991. Beginning in 1993 it was involved in a NASA, U.S. Air Force, and private industry flight research program called Advanced Control Technology for Integrated Vehicles (ACTIVE). The "F-15 ACTIVE" program concluded in 1999.

The plane was modified with new, computerized flight control systems, radical engines, and even control surfaces (canards) ahead of the wings to make it fly like no other F-15! More importantly, research done with this airplane helps in the design of future civil and military airplanes. Some of the programs developed for the ACTIVE include computer software that helps manage the engines and flight controls to reduce drag (allowing the plane to go faster with less power); noise-reduction research that may help supersonic airliners fly quieter; and an Intelligent Flight Control system that enables the plane's control systems to "think" of ways to adapt to equipment failures or battle damage so the plane could continue flying safely.