

Spitzer Space Telescope

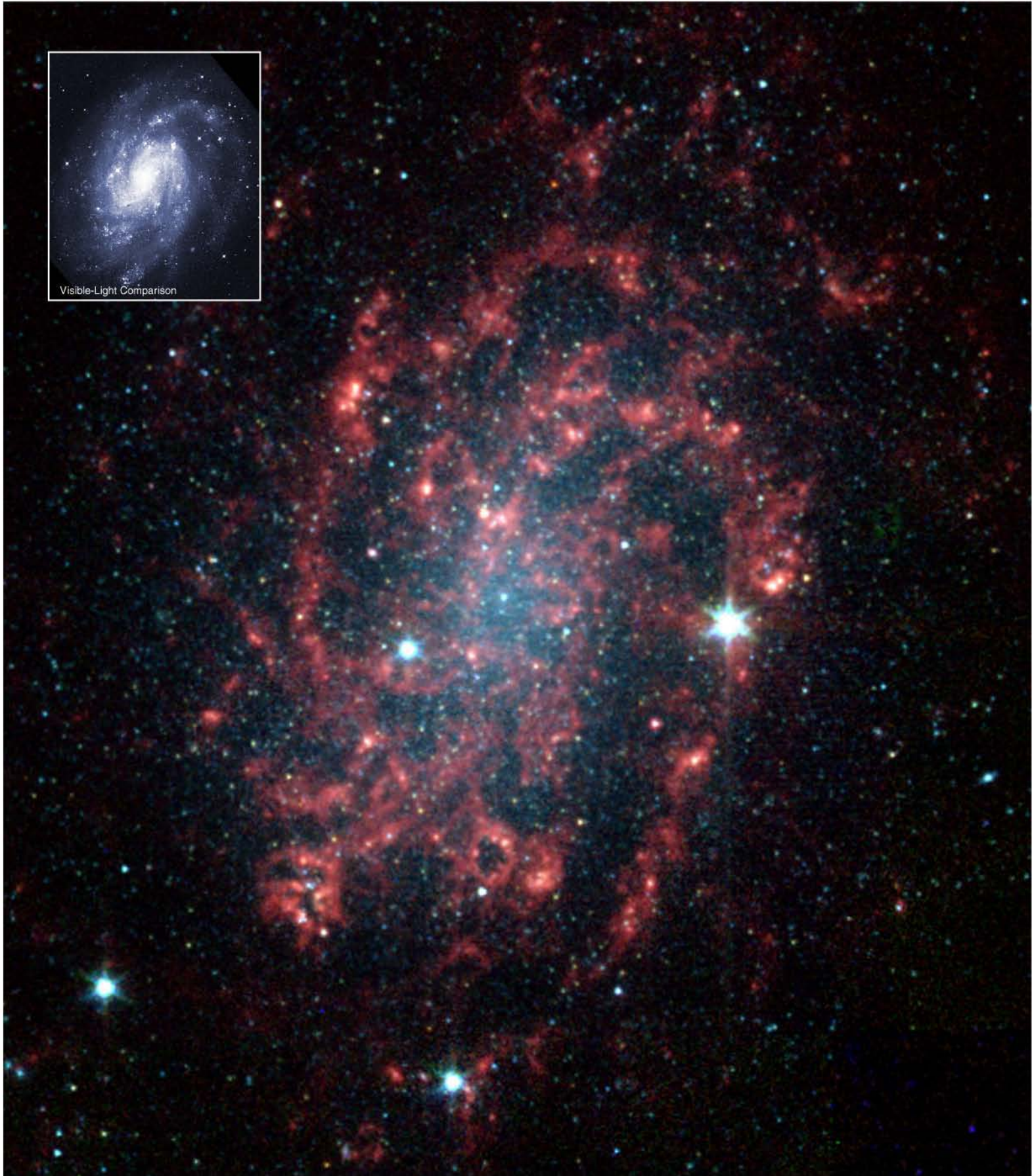

Galaxy NGC 300





Galaxy NGC 300

Taking Apart the Light

Sometimes, the best way to understand how something works is to take it apart. The same is true for galaxies like NGC 300, which NASA's Spitzer Space Telescope has divided into its various parts. NGC 300 is a spiral galaxy similar to our own Milky Way galaxy. It is about 7.5 million light-years away in the southern constellation Sculptor. NGC 300 is one of the Milky Way's closer neighbors. Consequently, it appears as a large object in the southern night sky, about half the size of the full moon. NGC 300's proximity and face-on orientation give astronomers an excellent opportunity to study the structure of this galaxy in detail.

Clearing the Dust

This false-color image taken by Spitzer's Infrared Array Camera is a composite of data from the near-infrared (shown as blue and green) and mid-infrared (shown as orange and red). In the near-infrared, the hot stars seen clearly in visible light fade out and cooler stars such as red dwarfs and red giants come into view. By comparing the visible-light image (inset) with the infrared Spitzer image, you can see several bright stars in the Spitzer image that do not appear in the visible-light image. You can see these stars because dust is transparent to near-infrared light, which allows us to see regions that are hidden by thick dust in visible-light images. In the mid-infrared, the cool dust itself glows from its own heat.

Spiral galaxies, which are rich in gas and dust, are strong infrared sources and are still forming new stars. By studying this Spitzer image, astronomers have gathered information about the main star component of the galaxy (near-infrared) as well as its dusty spiral arms (mid-infrared). The density of stars peaks strongly in the central bulge where older stars congregate and tapers off along the arms where younger stars reside.

Pollution in Space?

Thanks to Spitzer's unique ability to sense the mid-infrared emission (or heat) from dust, astronomers can now clearly trace the embedded dust structures within NGC 300's arms. When viewed in visible light, the galaxy's dust appears as dark lanes, largely overwhelmed by bright starlight. With Spitzer, the dust—in particular organic compounds called polycyclic aromatic hydrocarbons—can be seen in vivid detail (red). These organic molecules are produced, along with heavy elements, by the stellar nurseries found

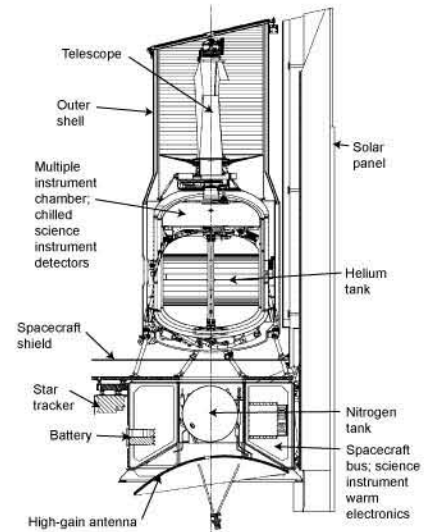

The Spitzer Telescope spacecraft is about 4 meters tall, with a mass of 865 kg.

throughout the galaxy's spiral arms. Polycyclic aromatic hydrocarbons are commonly found on Earth and are usually created by combustion processes. They are in the black parts of burnt toast, in the grit on your grill, and are generated by running a car or burning a candle.

Getting to Know Our Neighbors

By studying the details of dust, gas, and stars in galaxies within a few tens of millions of light-years, Spitzer provides a better understanding of the mechanics of spiral galaxies. In the future, this knowledge will help us understand more distant galaxies, whose individual components cannot yet be resolved.

This Spitzer image is a combination of four wavelengths of infrared light: 3.6 microns (blue), 4.5 microns (green), 5.8 microns (orange), and 8 microns (red). A micron is one millionth of a meter; a human hair is about 100 microns thick.

For more images from the Spitzer Space Telescope, see <http://www.spitzer.caltech.edu>.

The Jet Propulsion Laboratory, California Institute of Technology, manages the Spitzer Space Telescope for NASA.

Image credits:

Spitzer Image: NASA/JPL-Caltech/G. Helou (Caltech)
Visible-Light Image: Digital Sky Survey