

Constructing a Spectroscope

Objective



With adult supervision the student will construct a simple spectroscope.

Theory



All elements or pure substances, such as gold, silver, neon, or hydrogen, give off a set of wavelengths of light when they are heated. Scientists can study the light given off by stars and other objects in space or heated substances here on Earth and identify the kinds of elements that are present. In fact, the element helium, which is a very light gas, was discovered by studying the spectral lines of the Sun. Later, helium was found here on Earth. Scientists who study light use very complicated spectroscopes to observe and measure wavelengths given off by light sources.

Science and Mathematics Standards



Science Standards

- Science as Inquiry
- Physical Science

Mathematics Standards

- Problem Solving
- Communication
- Connection
- Computation/Estimation
- Measurement

Materials



- 1 cardboard box with lid
- sharp knife or blade
- 1 double-edged razor blade
- scissors
- black marker
- tape
- 1 manila file folder
- commercially purchased diffraction grating (plastic material with 13,440 grooves per square inch). (See List of Catalogs, page 83.)



Procedures

A-B
C-D

1. Make or adapt a box that is about 10 inches long, 6 inches wide, and 2 inches deep. The box must have a tight lid.
2. Use a black marker and color the inside of the box and lid.
3. Choose one end of the box and measure $\frac{1}{4}$ inch from the corner. **WITH ADULT HELP OR SUPERVISION**, cut out a 1-inch square hole.
4. Next cut a piece of diffraction grating $1\frac{1}{2}$ inches square.
5. Cut a frame of manila paper for the diffraction grating. The side measurements should be $1\frac{1}{2}$ inches square, and inside measurements for the hole in the frame should be 1 inch square.
6. Frame the diffraction grating and tape it inside the box to cover the 1-inch square hole cut in step No. 3, with lines of the diffraction grating vertical.
7. Directly opposite the diffraction grating on the other end of the box, measure and mark $\frac{1}{2}$ inch from the corner of the box and $\frac{1}{4}$ inch from the bottom. **WITH ADULT HELP OR SUPERVISION**, cut a hole 1-inch high and $\frac{1}{2}$ -inch wide.
8. Cut a rectangle of manila paper $1\frac{1}{2}$ inches by 2 inches. In the center of the manila rectangle, cut a small rectangular hole $\frac{3}{4}$ -inch high and $\frac{1}{4}$ -inch wide.

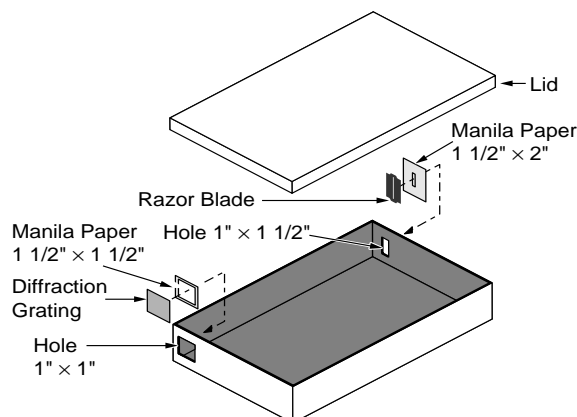

9. **WITH ADULT SUPERVISION**, break the razor blade into two pieces along the long hole in the blade. Place the sharp edges of the blade together to form a long narrow slit.
10. Mount the razor blade slit so that the long slit is parallel to the lines of the diffraction grating.
11. **WITH ADULT SUPERVISION**, center the slit in the double-edge razor blade over the opening in the large manila rectangular frame. Tape pieces of the blade in place.
12. Tape the framed razor blade to the outside of the box on the end opposite from the diffraction grating.
13. Place the lid securely on the box. Find a light source. Aim the razor blade at the light and look through the diffraction grating.
14. Observe the emission spectrum emitted by the light source.

Light, Color, and Their Uses

